

TAPESTRY LOOM

Large - 103cm (40") weaving width

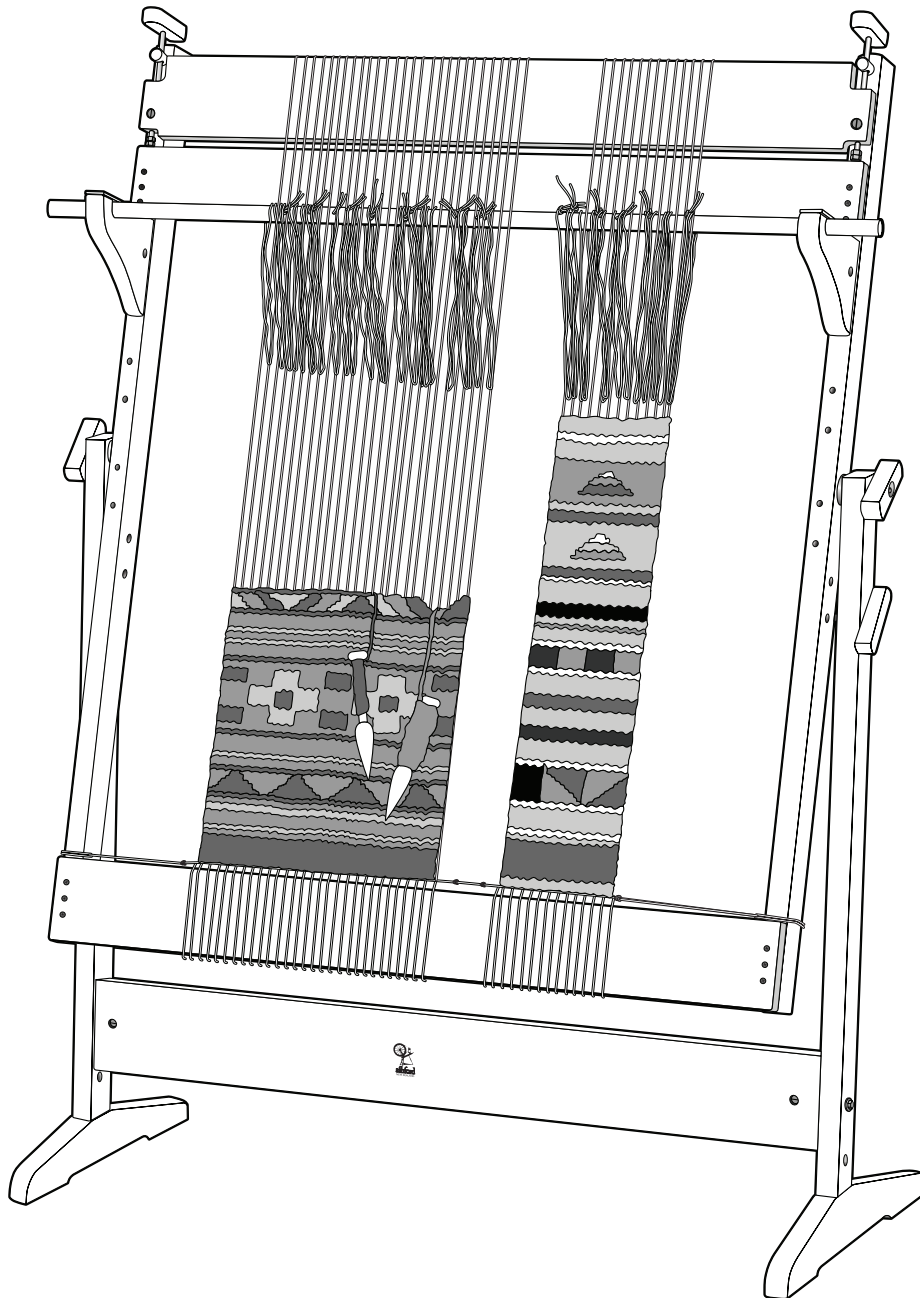

Includes warping and weaving instructions

TPLM17032017V5

ASSEMBLY INSTRUCTIONS FOR THE ASHFORD TAPESTRY LOOM

Loom Assembly

Step 1.

Push the nylon bushes into the holes in the top rail.

Step 2.

Attach the top rail to the loom sides using 50mm (2") screws. Check the nylon bushes face up & the top rail & sides are at right angles.

Step 3.

Attach the bottom rail to the loom sides with 50mm (2") screws. Check the rails & sides are at right angles.

Step 4.

Locate a barrel nut into the hole in the warp tension rail. Thread the metal tension knob down through the projecting dowel, through the rail, barrel nut & then thread on 2 nuts. Leave approx. 20mm ($\frac{3}{4}$ ") of thread projecting past the nuts to locate into the nylon bush. Use 2 spanners to tighten the nuts against each other. Repeat for the other side.

Step 5.

Attach the leash rod clamps to the support block with 25mm (1") screws. Glue a wooden dowel into the lower hole in a leash rod support. Allow glue to dry. Position a barrel nut into the leash rod support & thread a 100mm (4") hex head bolt & small washer into it from the back of the loom. Repeat for the other side. Note the 3 positions allow the supports to be lowered if required.

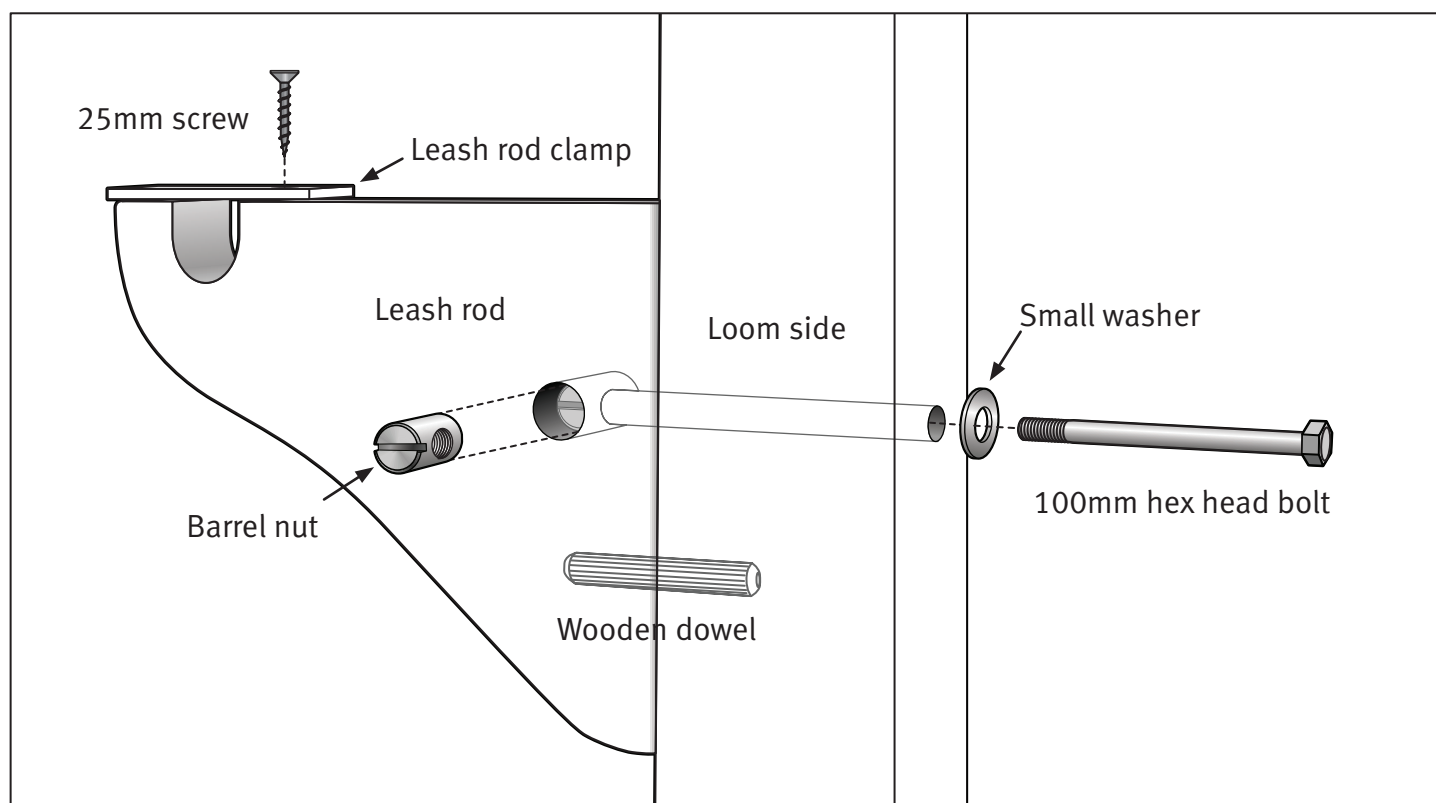
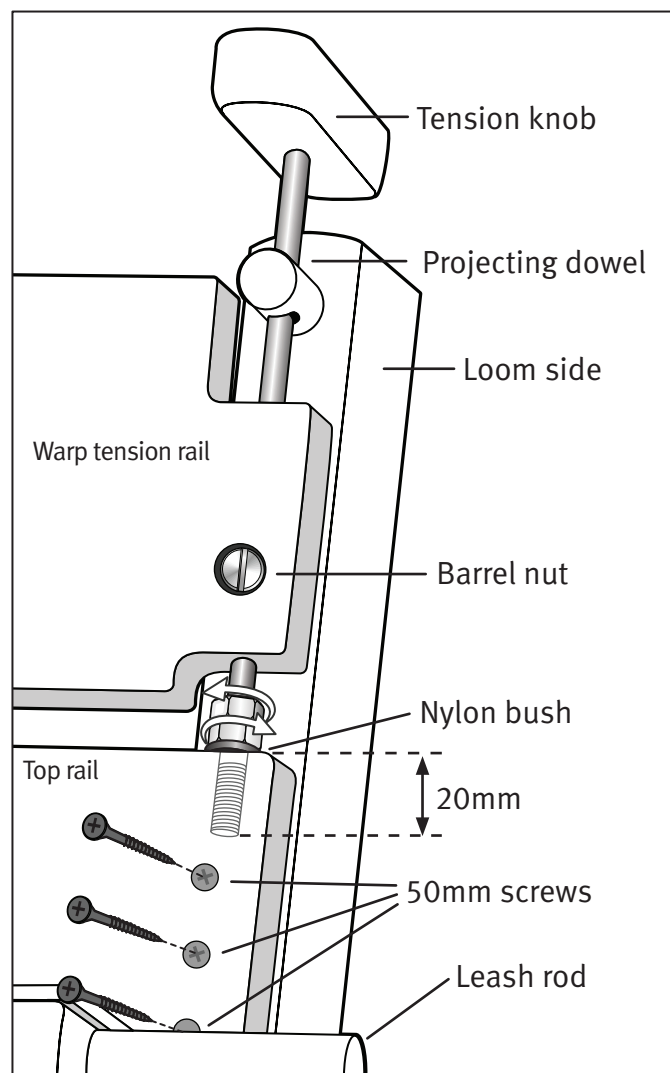

Floor Stand Assembly

Step 6.

Locate 2 wooden dowels into the holes in a foot. Position a leg onto the foot & secure with a 130mm (5") bolt, small washer & barrel nut. Note the legs lean back. Repeat for the other side.

Step 7.

Locate wooden dowels into the 2 outside holes in both ends of the bottom spacer & then secure between the legs with 80mm (3 1/4") hex head bolts, small washers & barrel nuts.

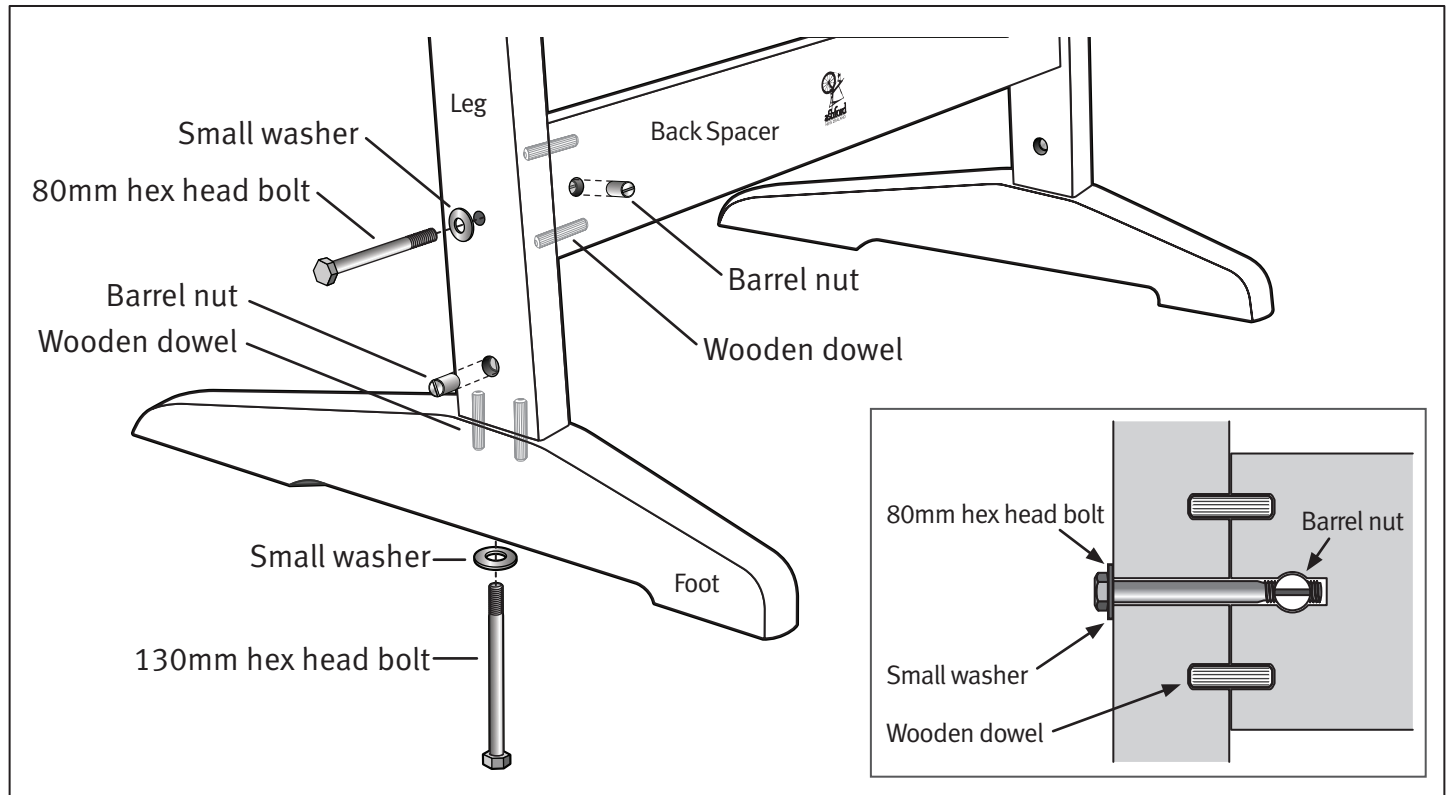

Attach the Loom to the Floor Stand

Step 8.

Position the loom between the floor stand. Push 2 x 100mm (4") round head bolts through from the inside of the loom, through the wooden spacers, through the top holes in the legs & secure with large washers & handles. Note the large hole in the handle must be to the outside. Hammer the bolt heads into the loom sides rather than tightening the handles.

Step 9.

Locate the locking peg through a hole in the loom side & into the stand to prevent the loom rotating. Locate the leash rod into the leash rod supports & lock in place.

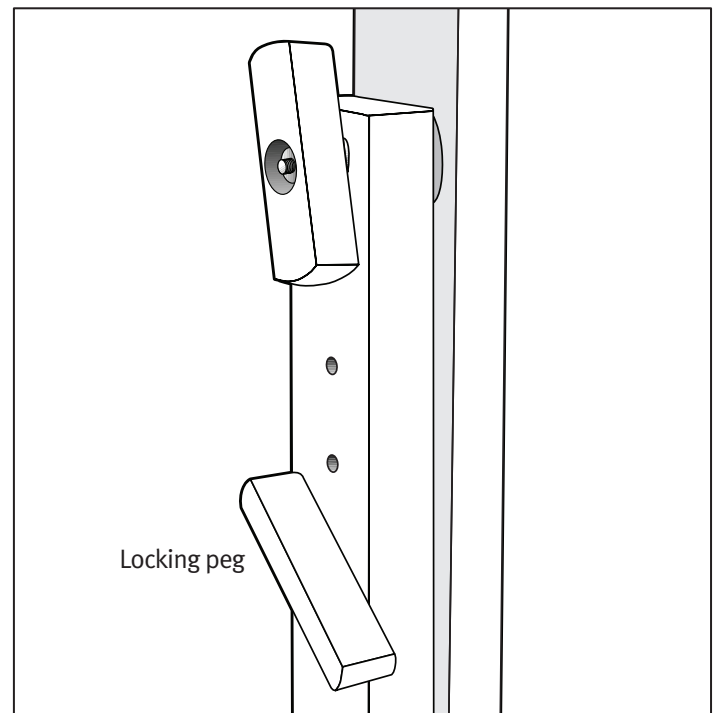
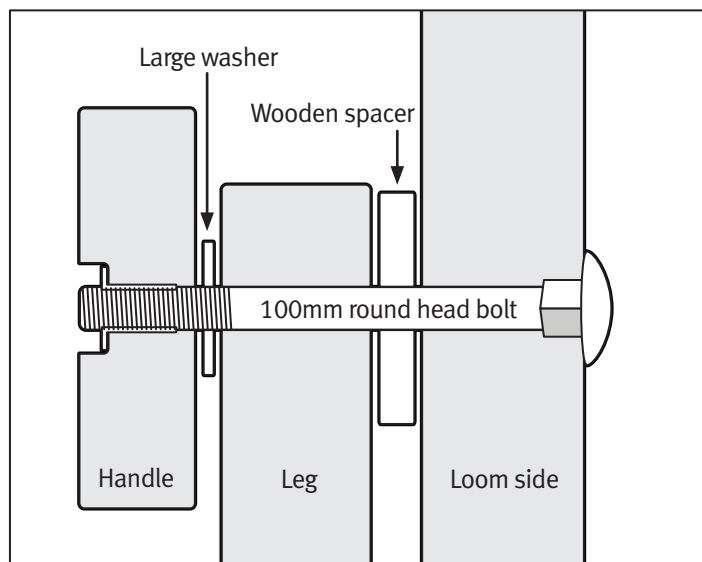

Warping Instructions

Tools required

Pencil, ruler, scissors, Ashford Tapestry Beater, Ashford Tapestry Loom Warp Thread (7 wraps per cm or 17-18 per inch) for the warp, weft yarns of your choice.

Step 1.

Remove the locking peg & leash rod.

Step 2.

Decide on the width of your first tapestry.

Step 3.

On the outside edges of the top & bottom rails,

mark the centre in pencil. From the centre, mark lines every 12.5mm (1/2") according to the width of your tapestry. Pencil can be rubbed out & the lines re-marked for your next tapestry.

Step 4.

Adjust the tension knobs so the top rail is in the middle of its adjustable range. Check the tension knobs face front to back.

Step 5.

Tie the end of the warp thread to the bottom rail on the mark indicating the left side of your tapestry.

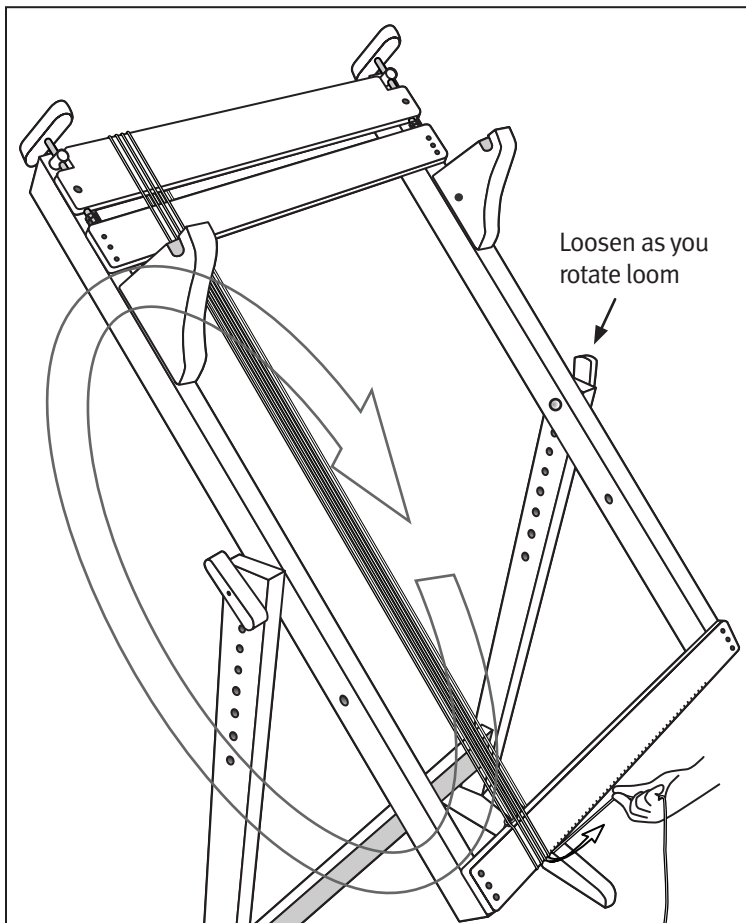
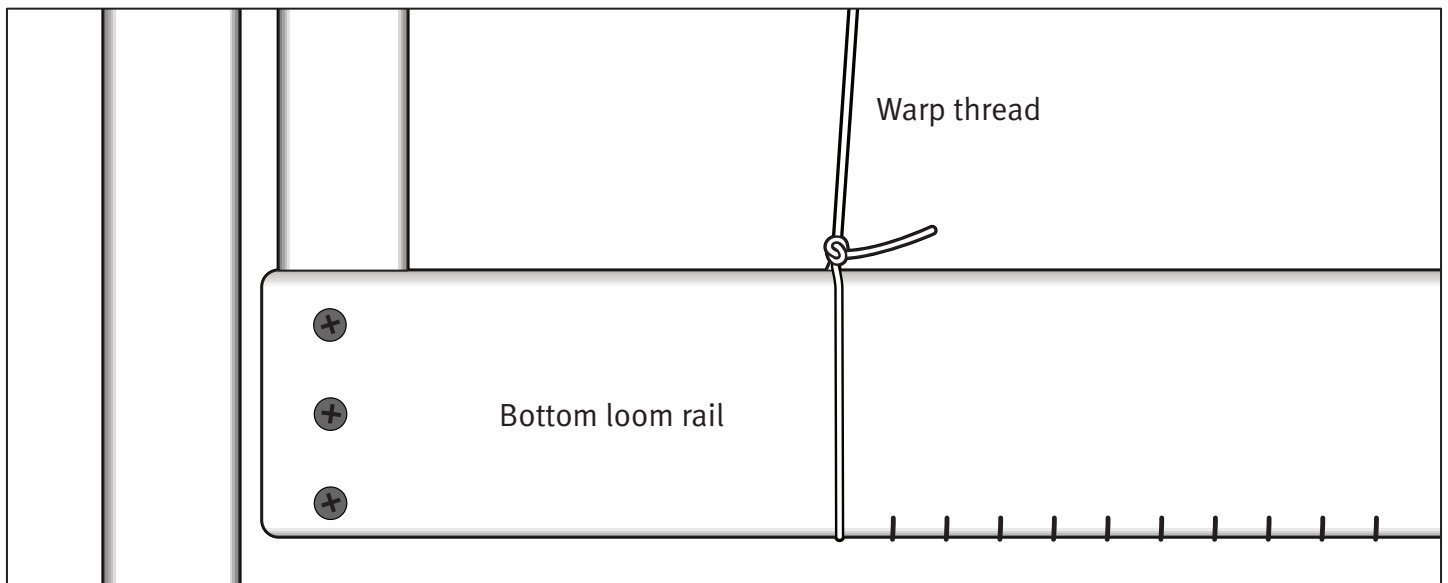

Step 6.

Loosen the handles on either side to enable the loom to rotate easily. As you rotate the loom you may need to adjust the handles to prevent the loom locking.

Step 7.

Sit down in front of the loom, hold the warp thread & ask a friend to rotate the loom towards you. Place the warp thread on the marks on the top & bottom rails the same distance from the centre. Keep rotating the loom until you have the required number of threads. Keep a firm/even tension on the warp thread.

Step 8.

Tie the warp thread to the bottom rail & cut it off.

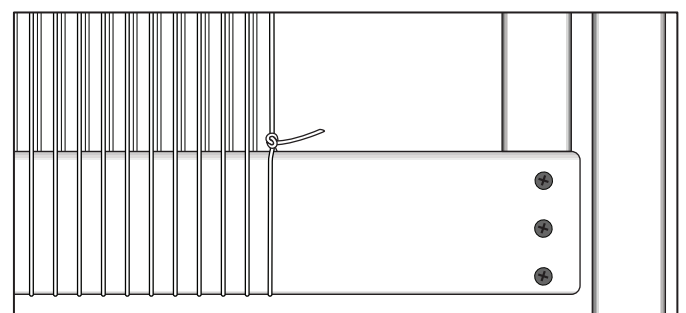

Step 9.

Check all the warp threads are on a pencil mark.

Step 10.

Sit down, position the loom on your knees & tighten the handles.

Step 11.

Turn the 2 tension knobs to tighten the warp as necessary.

Step 12.

Place the locking peg into a hole in either leg to prevent the loom rotating.

Step 13.

Twining. This binds the back & front threads together at the bottom. Note. Do not twine the first & last warp threads as they act as guide threads to show you that the edges of your tapestry are straight. Cut a piece of warp thread 3 times the width of the loom. Fold the thread in half & form a loop around the left loom side at the bottom. Tie an overhand knot just to the left of the guide thread. Weave one row of twining bringing one back thread & one front thread together across the row. Make an overhand knot to the right of the guide thread. Then tie off on the opposite side.

Step 14.

The loom is now ready for you to start weaving. If desired, leashes can be used to bring the back threads forward. Leashes are made from pieces of warp thread 105cm (42") long, tied in loops. Place the leash rod in position on the supports & lock in place. To thread the leashes onto the warp, hold the rod so one end is above the left hand side of the warp. Loop a leash onto the rod, wrap it around the first back warp thread & loop it back onto the rod. Move the rod along as the leashes are loaded to prevent them falling off.

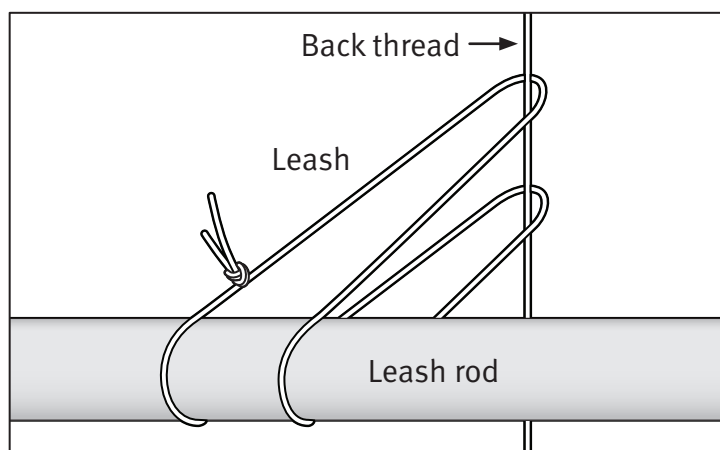
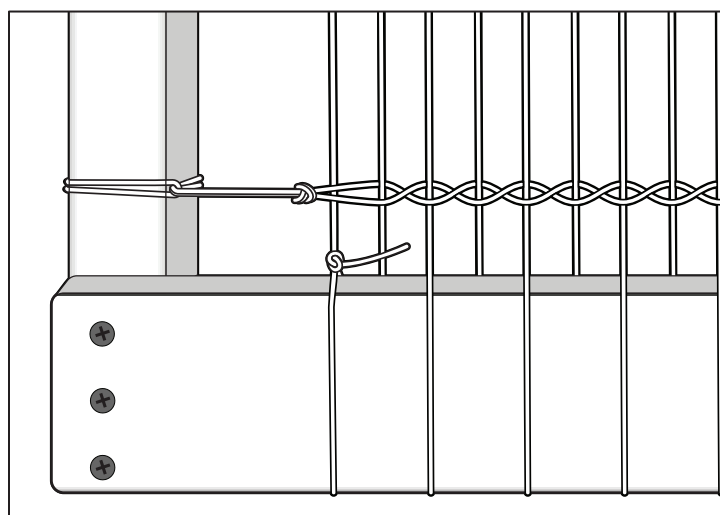
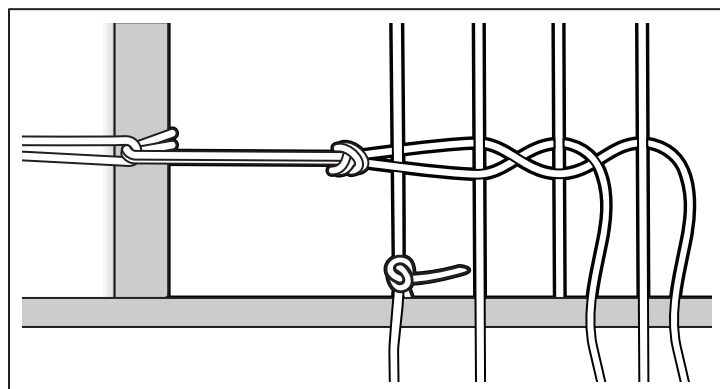

Weaving instructions

Step 1.

To create the first weaving space (shed) for the weaving thread (weft), slide your fingers behind a group of front threads (no leashes) & pull forward. To create the second weaving space, gently pull down on a group of leashes to bring the back warp threads forward through the front threads. We recommend picking up 4 to 6 warp threads each time.

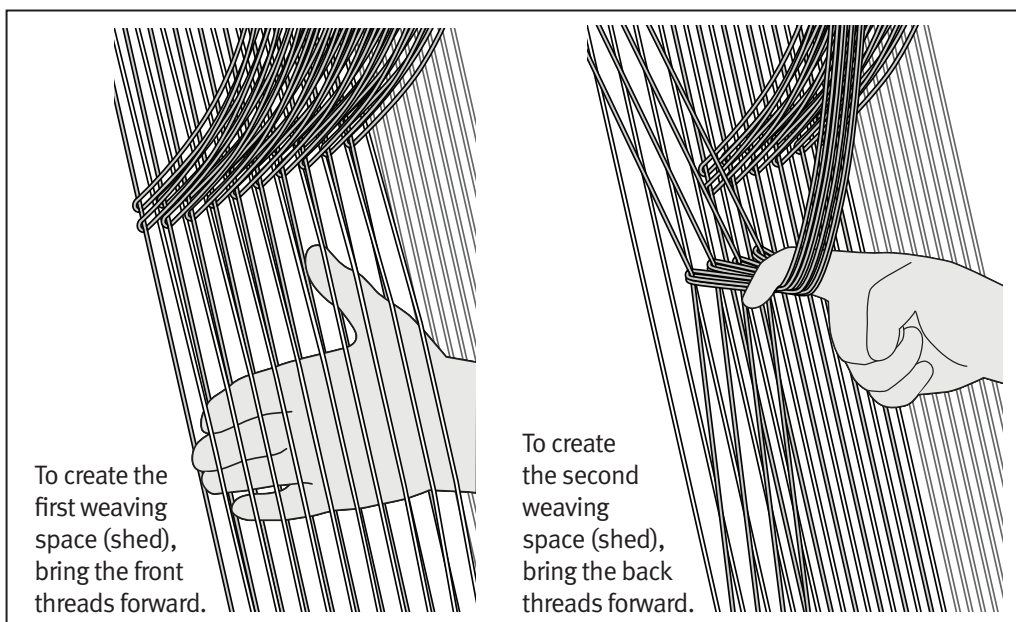

Step 2.

Fill the bobbin with your weft thread. Take 2 ends of yarn & wind clockwise, evenly onto the bobbin, until level with the bobbin end covering the end of the yarn.

Step 3.

It is important in tapestry weaving to “bubble” the weft before it is beaten down into place. The weft forms the woven fabric & the warp is not seen. When the bobbin is not in use, secure it with a half hitch knot.

Step 4.

Beat the threads down with the pointed end of the bobbin.

Step 5.

Weave in comfort with the loom resting on your knees. Note the holes in the stand allow for height adjustment. As the weaving progresses, you can lower the loom by repositioning the bolts.

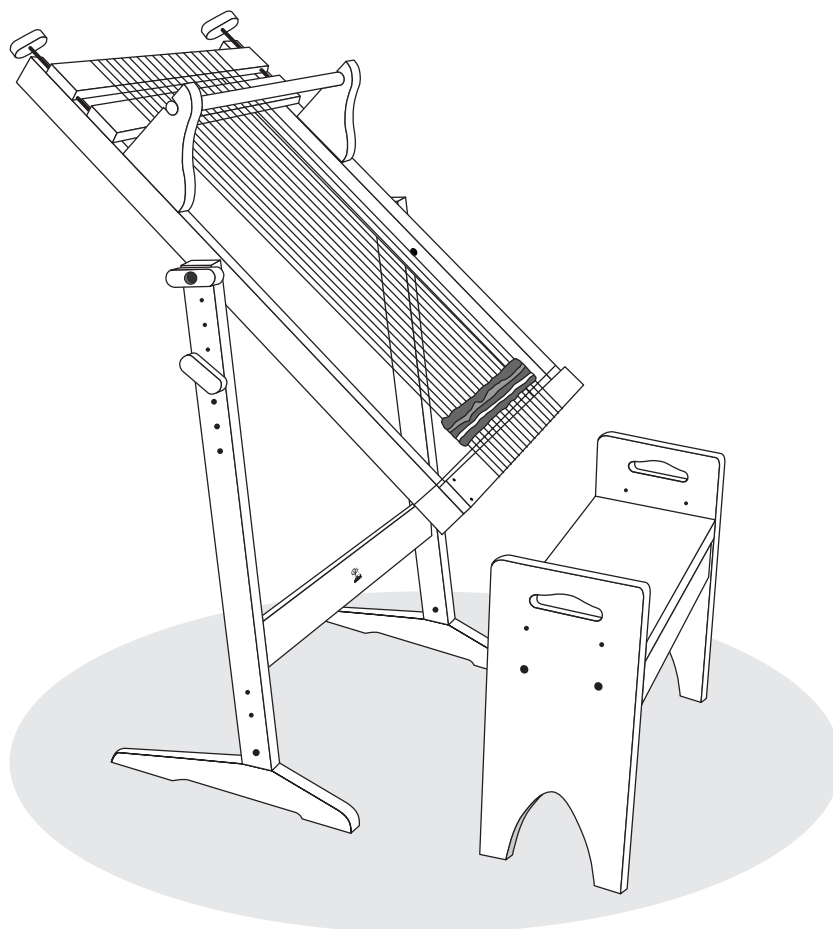
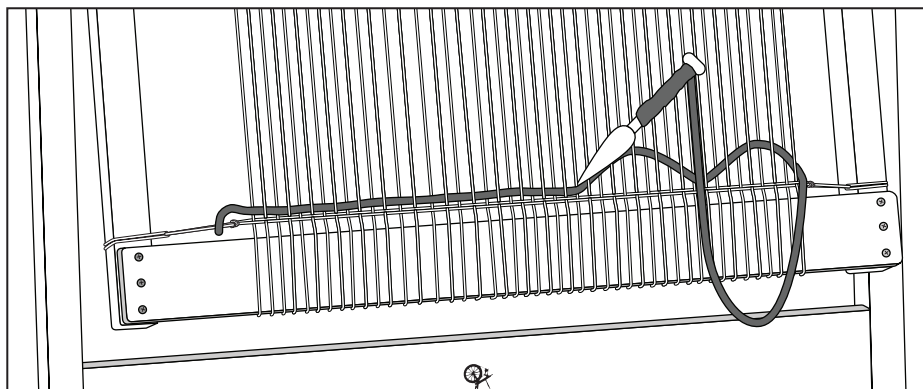
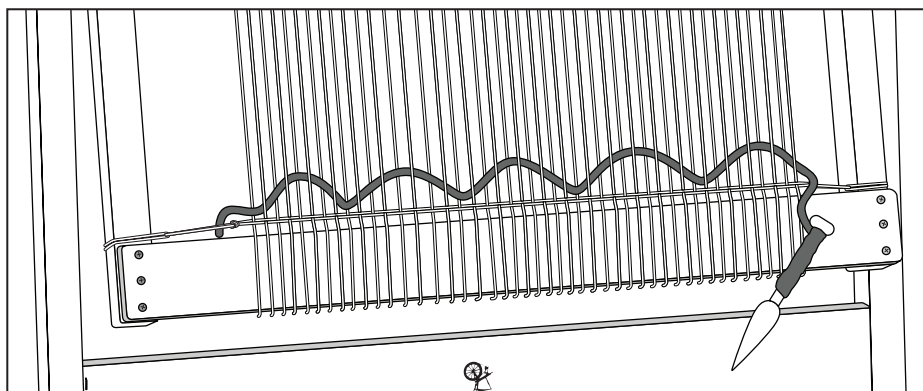

Weaving Accessories

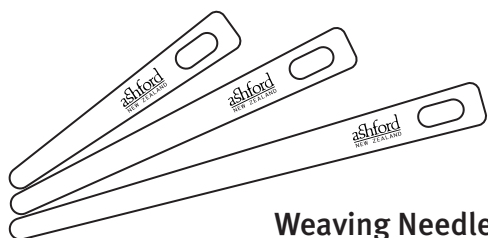

Weaving Needles

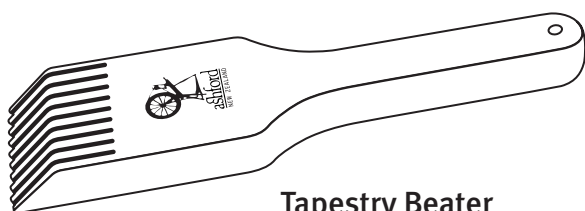

Tapestry Beater

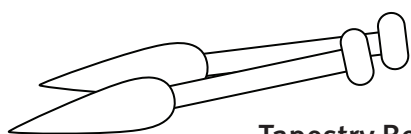

Tapestry Bobbin

For more weaving tips, ideas and techniques refer to The Ashford Book of Rigid Heddle Weaving and www.ashford.co.nz