

FRINGE TWISTER

Make a perfect twisted fringe on scarves, handwoven garments or needlework projects.
Create cording from cotton or twist sliver for fibre craft projects. Add beads and metallics for texture and fun.

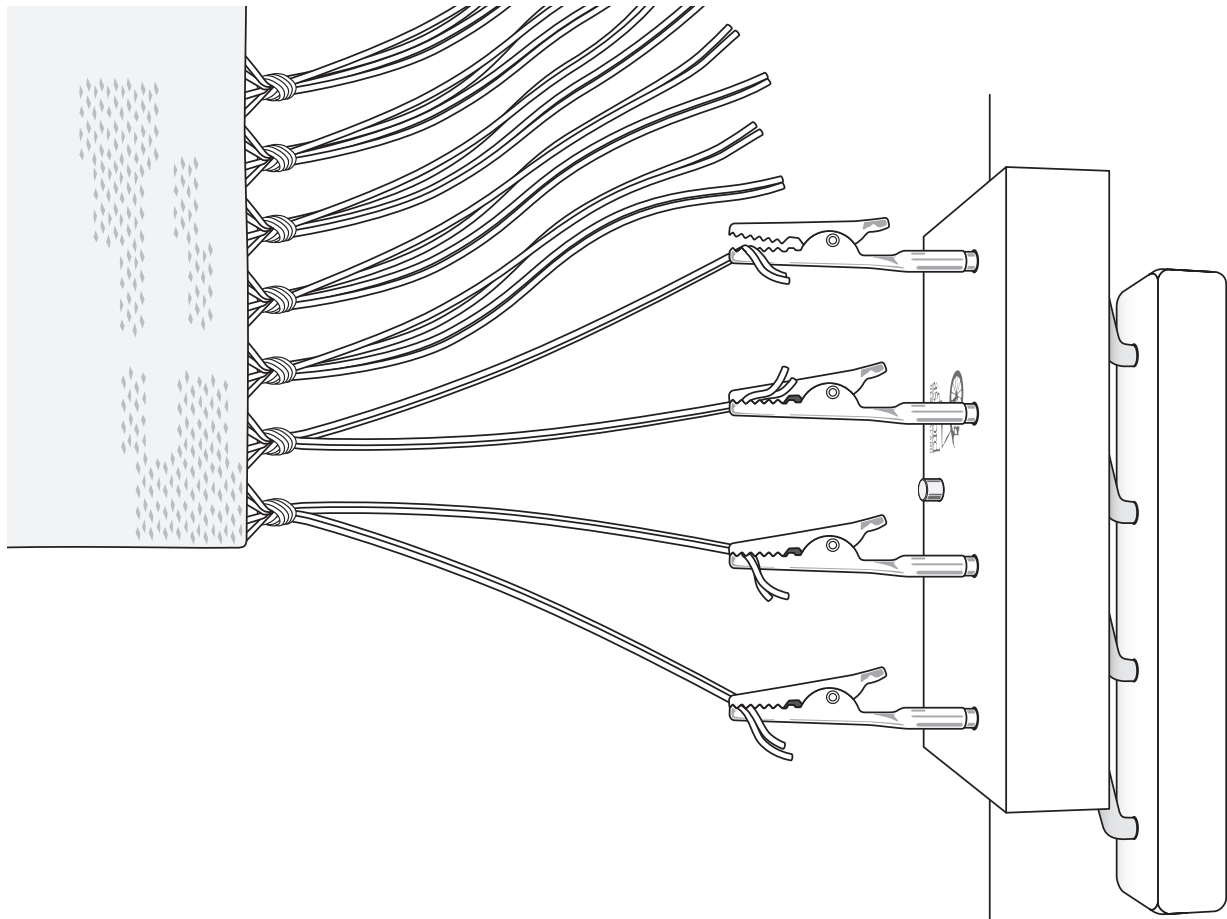

FT409022012V2

Twisted fringe

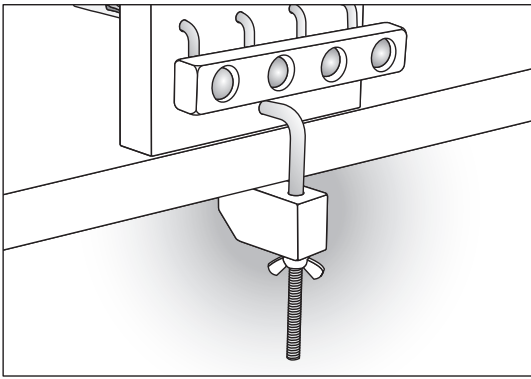

1. Clamp twister to a table.

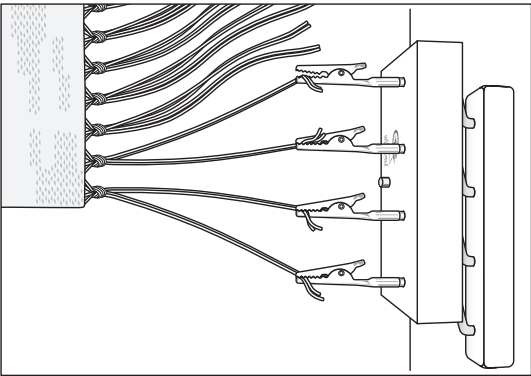

2. Divide into groups of desired thickness.
Hint: Usually 4 – 6 wool strands or 6 – 8 cotton warp ends work well for most items.
3. Take the first group and divide in half, clamp each half in a clip. Do the same with the next group.

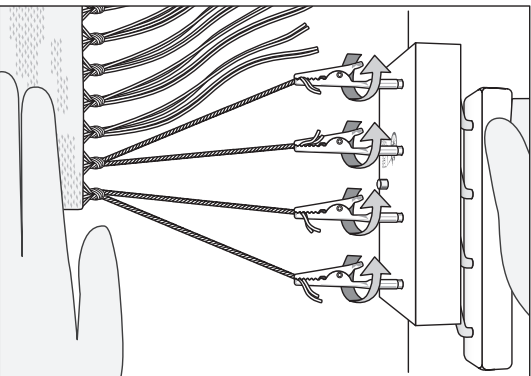

4. Place a hand on the garment to keep tension on the stands clipped to the twister, turn the handle clockwise as many times as desired (take note of how many rotations, and repeat across fringe, this will ensure an even twist and length).

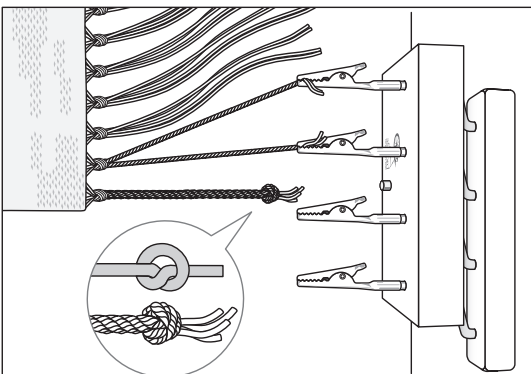

5. To ply, remove from clips and finish by knotting the two halves together close to the end. The two halves will twist anticlockwise to create the fringe.
6. Repeat from step 1, working along the garment.

Twisted sliver

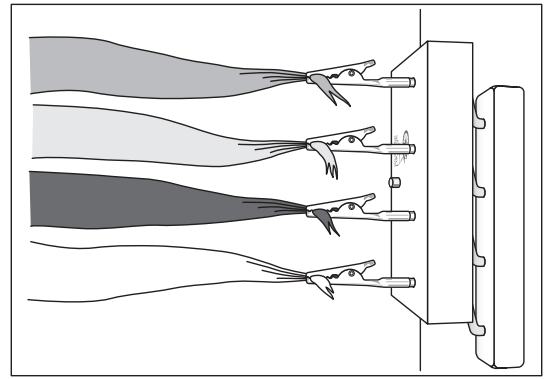

1. Clamp twister to a table.
2. Divide sliver into even desired thicknesses. Clip each length in place.

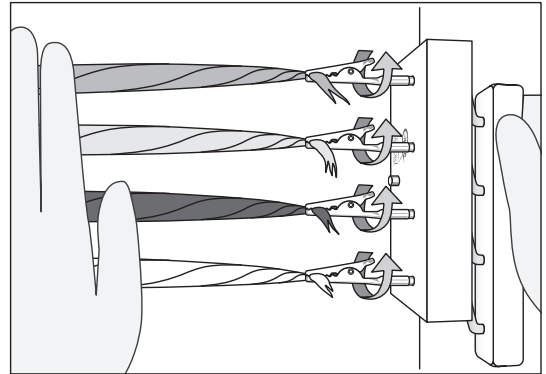

3. Place a hand on the ends of the sliver and rotate the handle clockwise until the sliver is twisted.

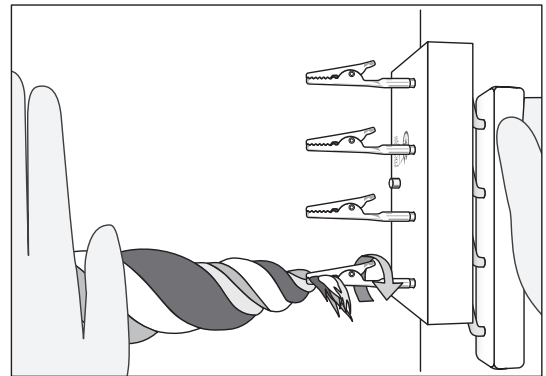

4. Holding onto the ends, unclip and place all 4 opposite ends into one clip and rotate anti-clockwise.

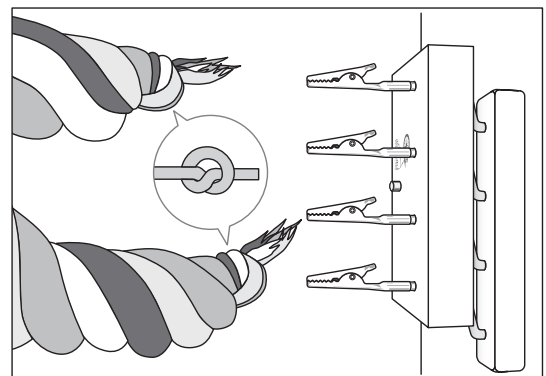

5. Tie a knot in each end to secure.

Hints:

- Twisted sliver can be felted by hand or in your washing machine.
- If handle squeaks, apply a drop of oil to the shafts.
- Hold handle in the centre, pull away and turn gently.