

TRADITIONAL SPINNING WHEEL

DOUBLE DRIVE

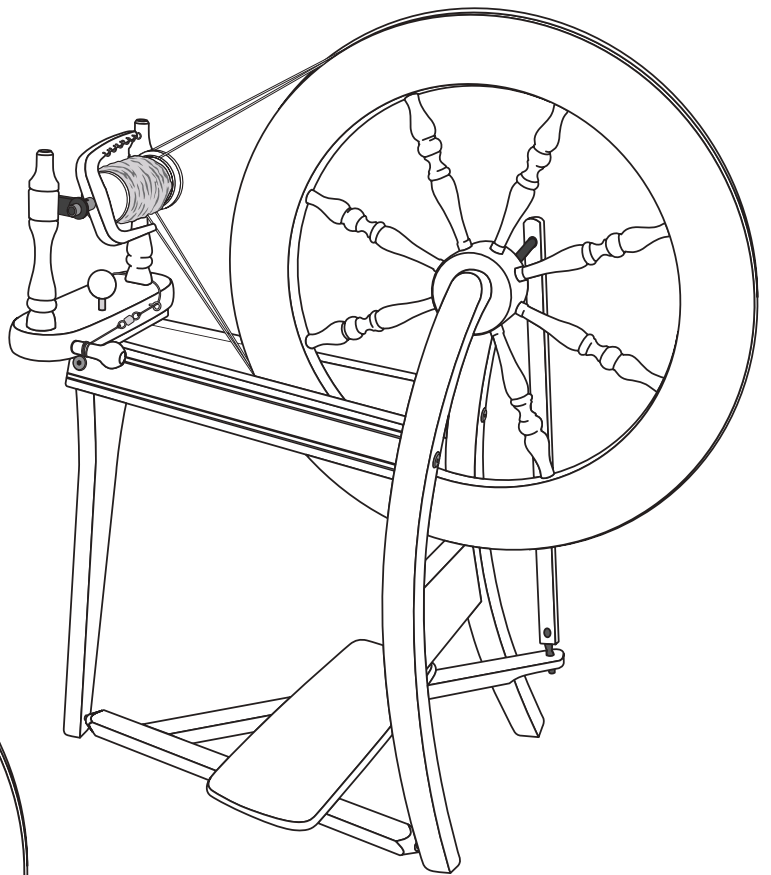

SINGLE DRIVE

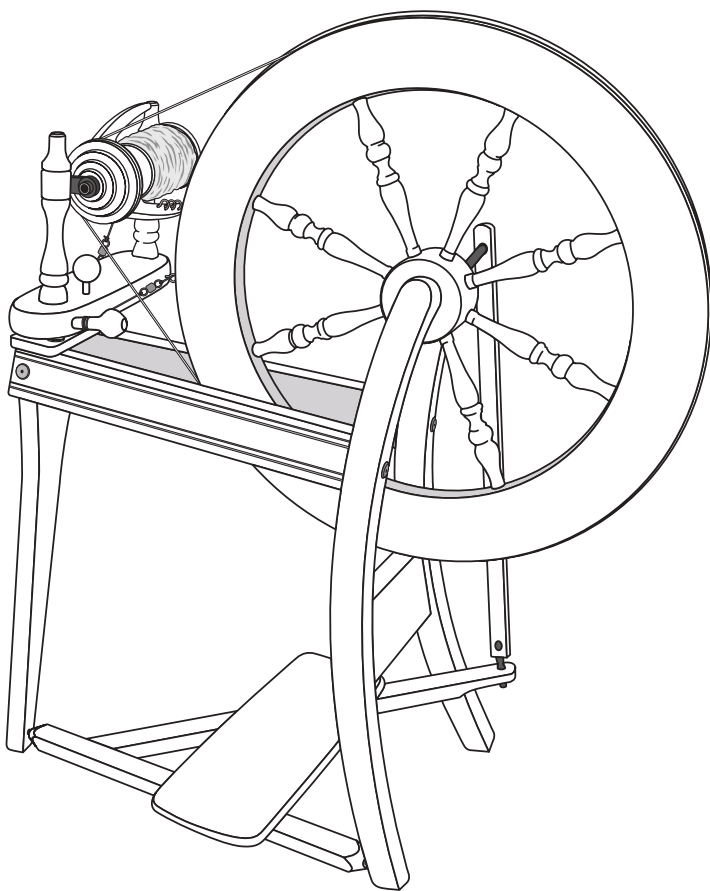

TDSW-DDSW120922V5

ASSEMBLY INSTRUCTIONS FOR THE ASHFORD TRADITIONAL SPINNING WHEEL

Before commencing, please read these instructions completely, identify the parts and note the assembly sequence.

Remove any sharp corners or edges and smooth the surface of the wood with the sand paper provided. We recommend that the wood surfaces be waxed or sealed before assembly. This protects the kiln dried wood from the climatic changes and prevents it getting dirty or stained.

The Beech timber has a lovely variety of colour and grain. For a silky smooth matt finish, use the Ashford Finishing Wax Polish to enhance the natural colours and character of this timber.

If you are assembling your spinning wheel on a table, we recommend you protect the surface with a towel, blanket or cardboard.

Ashford spinning wheels are also available factory finished in clear lacquer.

Tools Required



included

Hints

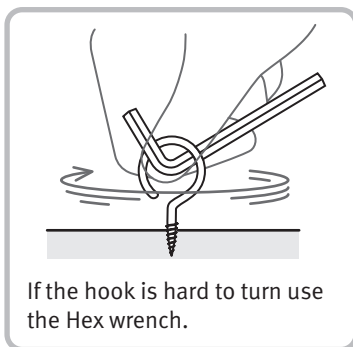
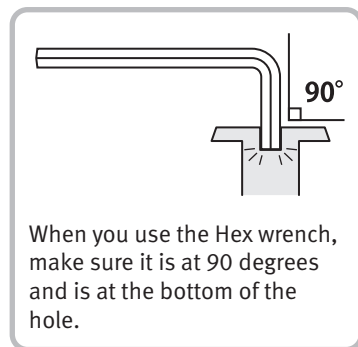
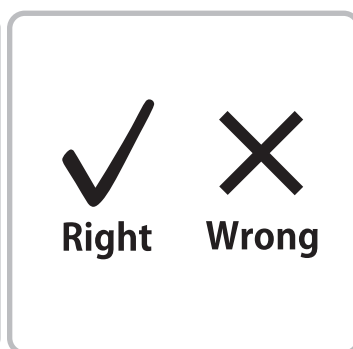
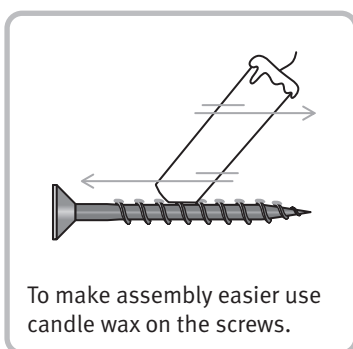
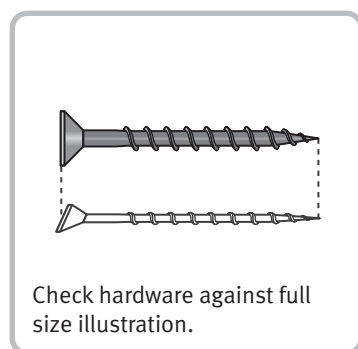

More Information



How-to videos on You Tube
Watch our how-to videos on You Tube.
www.youtube.com/user/AshfordHandicrafts



Facebook
Join us on facebook.
www.facebook.com/ashford.wheels.looms

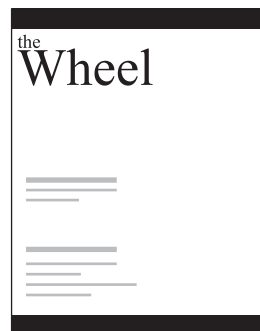

The Wheel Magazine
Ashford's annual fibre craft magazine. Spinning, weaving, felting, dyeing and knitting projects, patterns and articles from around the world. To receive the glossy version delivered to you, subscribe at: www.ashford.co.nz/subscribe

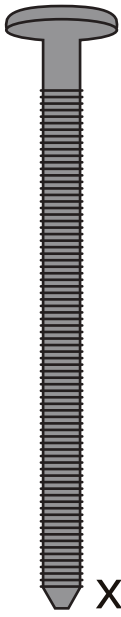

x2

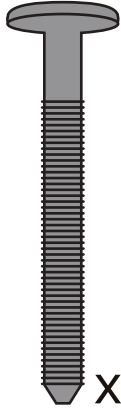

x2



x2



x2

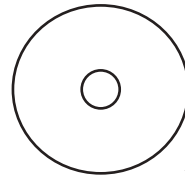

x4



x1



x1



x4



x2



x1



x13



x1



x1

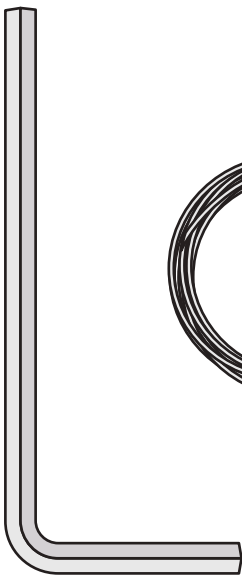

x1

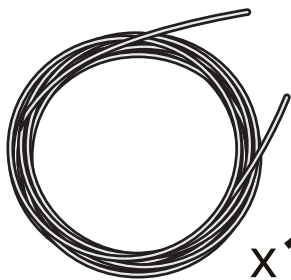

x1

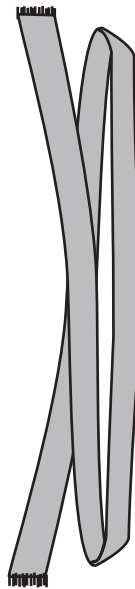

x1

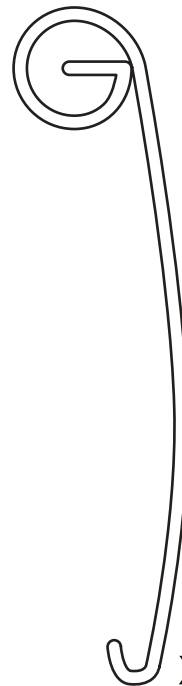

x1

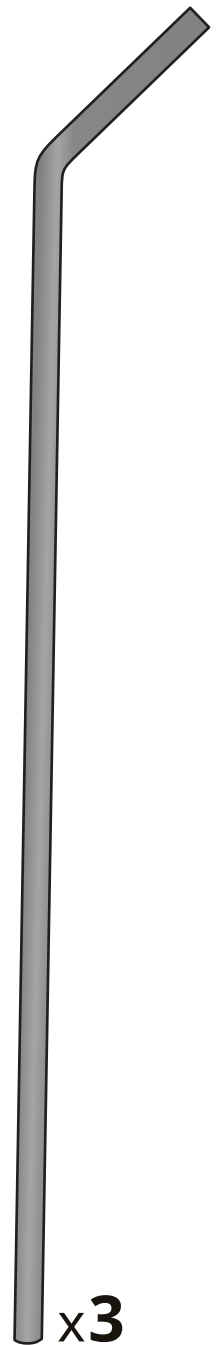

x3

1



Check the small hole is on the top of the side rails.

Attach the side rails to the single leg with bolts and barrel nuts.

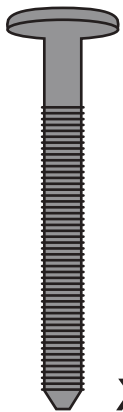
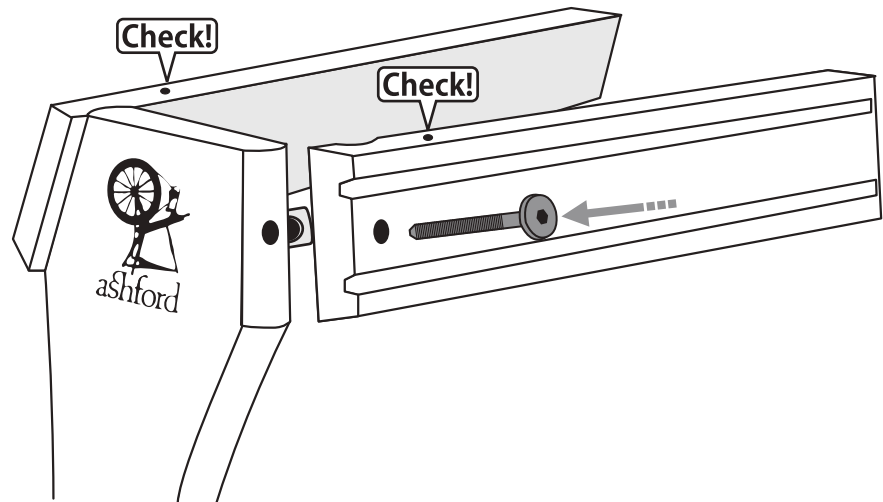

x2



x2

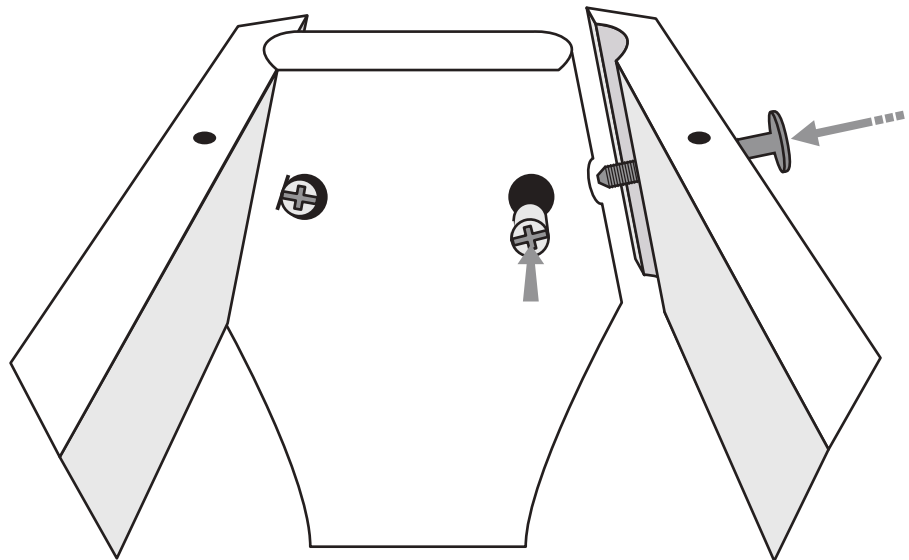

2



Check the angle of the side rails and tighten.

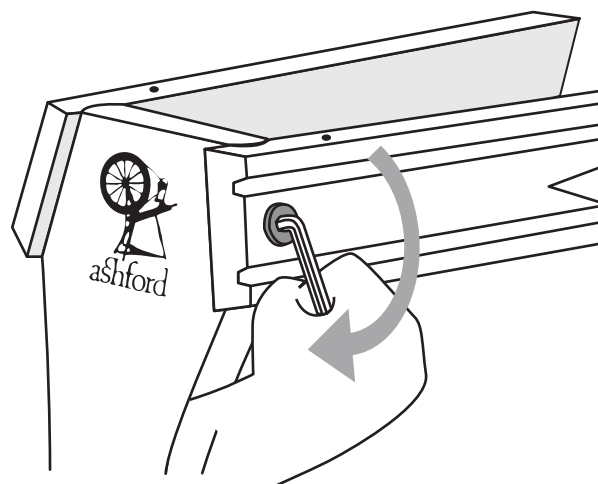

Check!

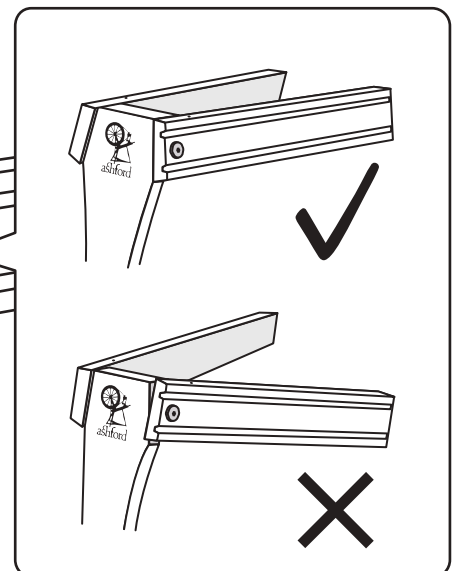

3

Set the treadle assembly on the edge of a table.
Insert the conrod joint into the large slot in the treadle rail.
Note the crank bearing faces the back of the spinning wheel.

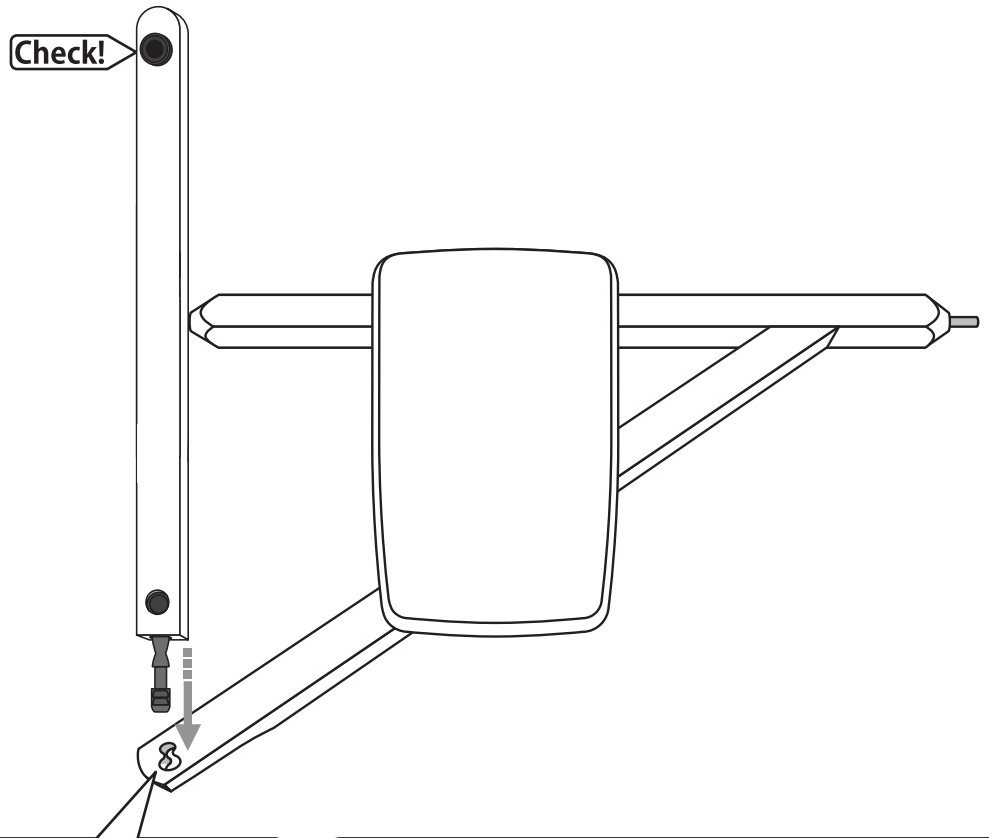

1

Hold the conrod joint with one hand on either side of the treadle rail.

2

With both hands, turn the conrod joint a $\frac{1}{4}$ turn.

3

Stretch and slide it into the small slot and turn it back a $\frac{1}{4}$ turn until it clicks into place.

4

4



Wax the steel rods in the treadle rail.

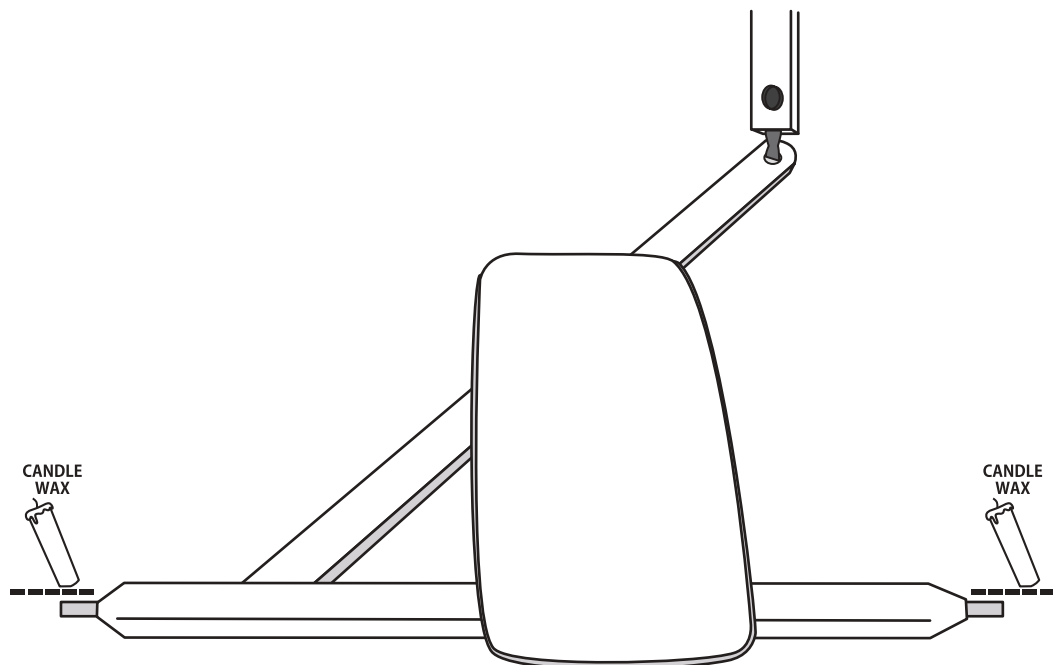

5



Loosely attach the wheel support to the side rails with bolts and barrel nuts. Then locate the treadle rail into the holes in the legs.

Check!

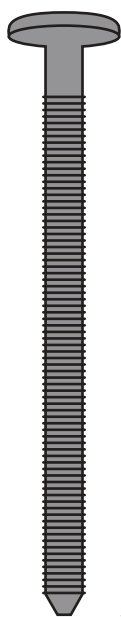
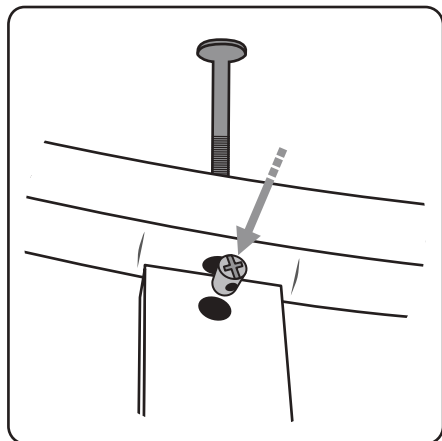

x2



x2

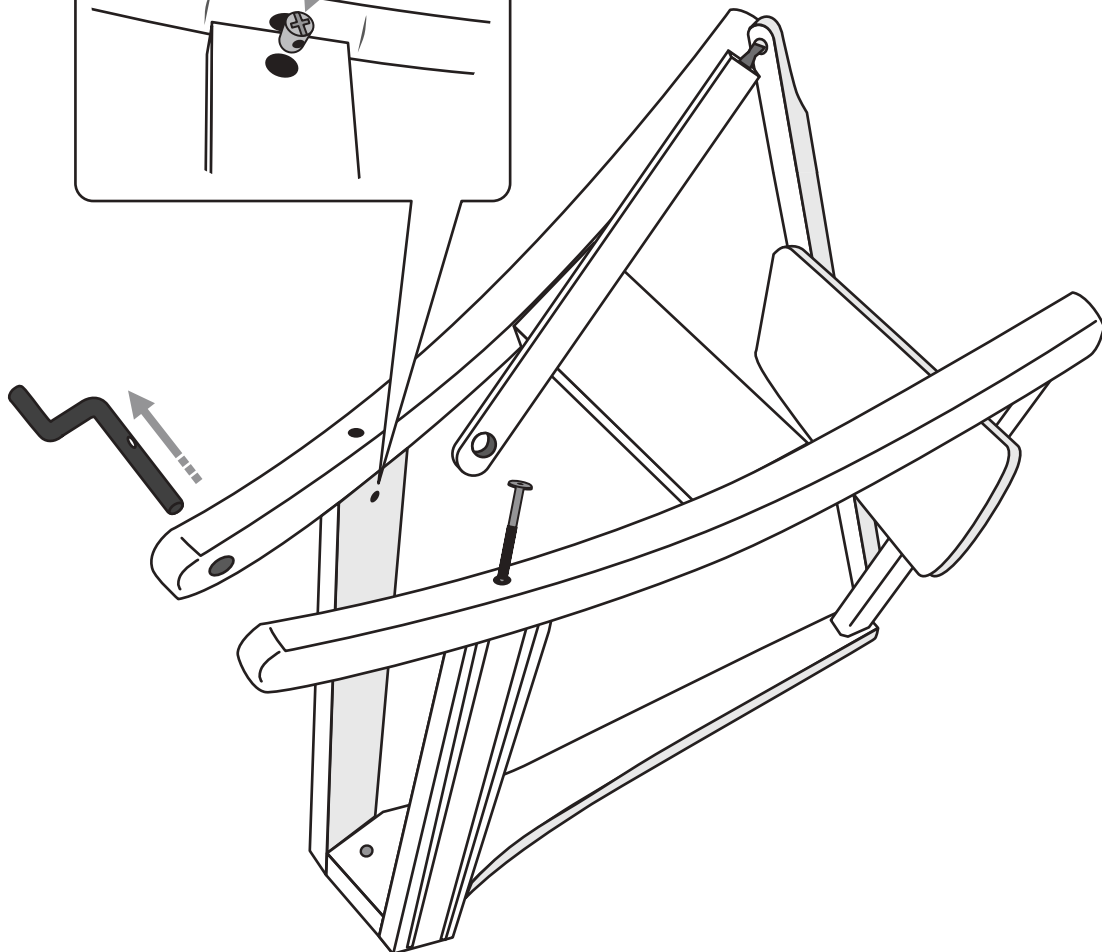

6

Check the angle of the single leg.

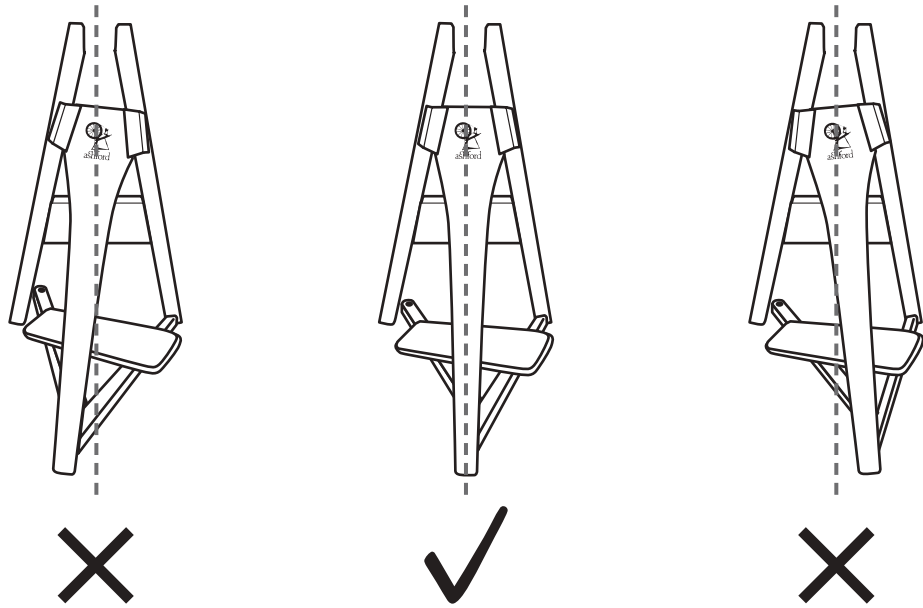

7



Insert the crank shaft into the wheel support. Tighten every bolt extra firmly with the Hex wrench. Then remove the crank.

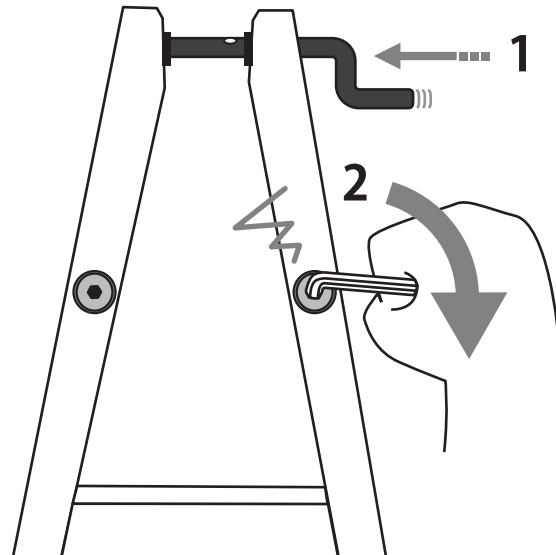

8



Before placing the wheel in position, check the crank fits through the hole in the hub. Wax and insert the crank shaft then remove.

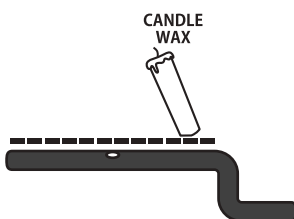

Check!

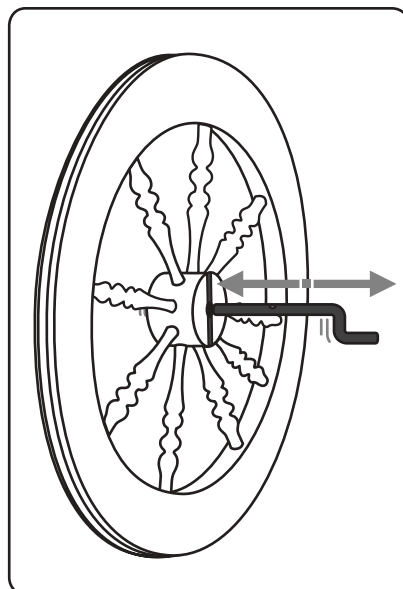

Place the wheel in position.

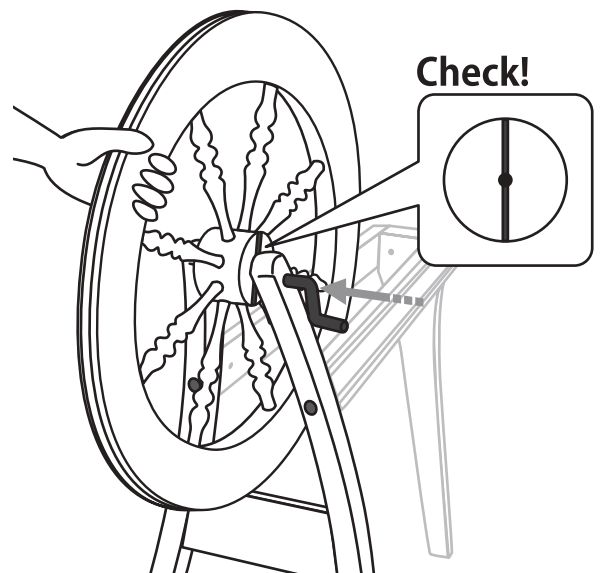

9

Align the wheel and hole in the crank shaft with the groove in the hub using a lazy kate wire.

Check!

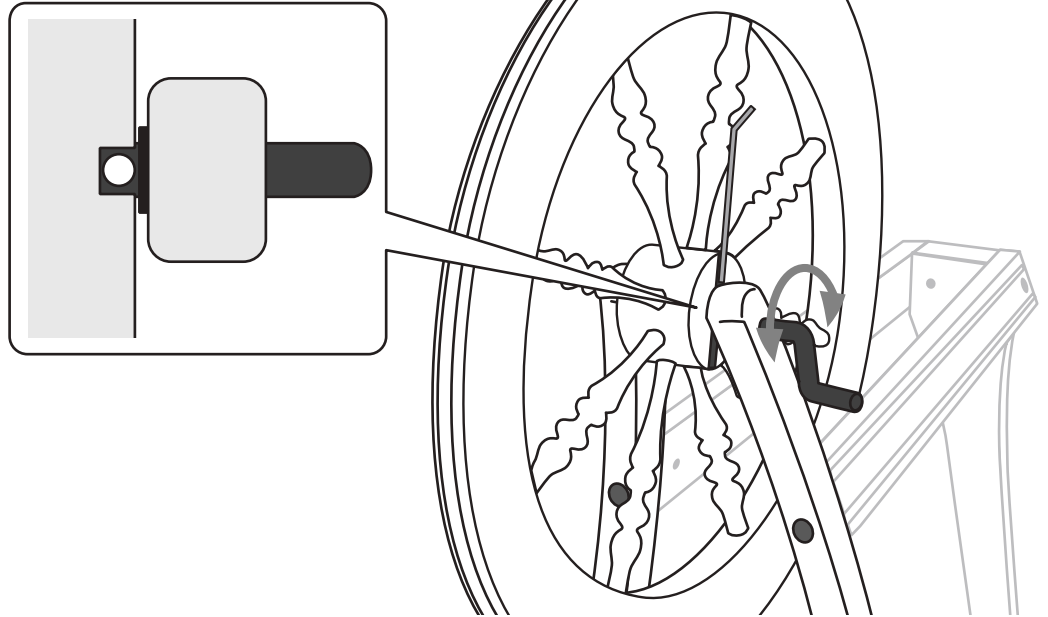

10



Carefully tap the hub pin through the hub and crank.

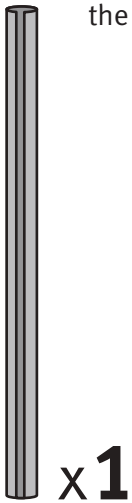

x1

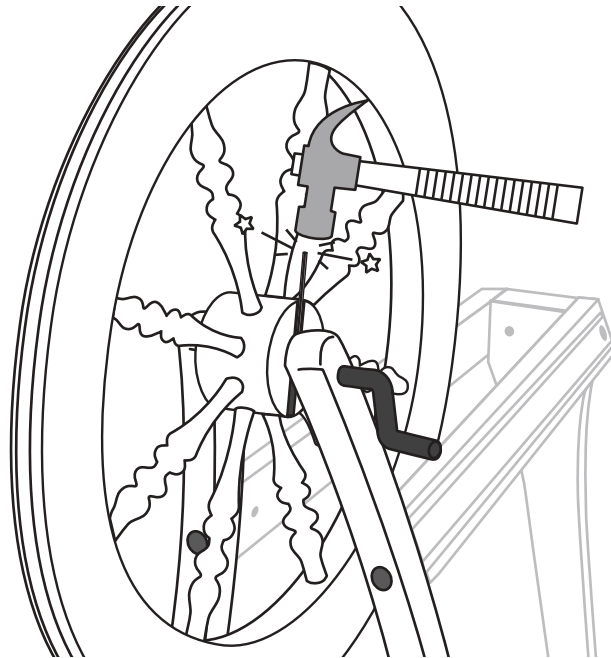

Check!

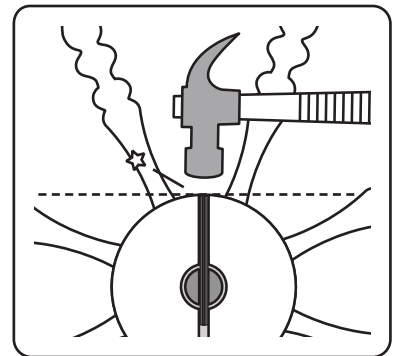

11



Slide the inner shell of the conrod universal joint onto the crank until it clicks into the groove.

Apply a drop of oil to this bearing and click the conrod onto the inner shell of the conrod joint.

Note: The ball bearings are sealed for life and **do not** require oiling.



x1

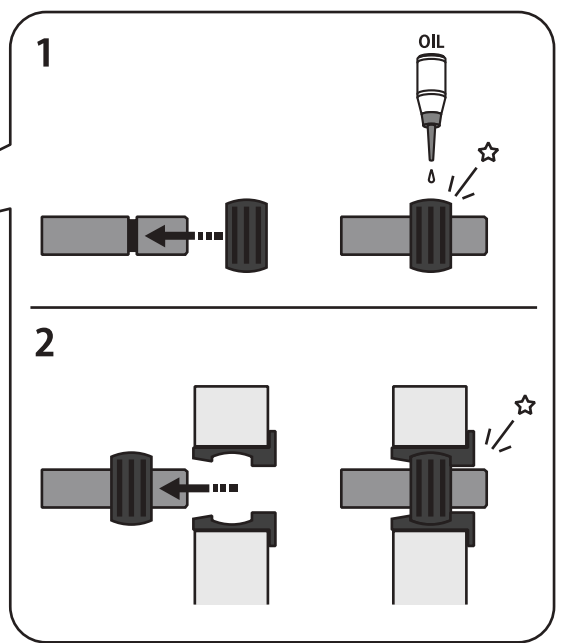
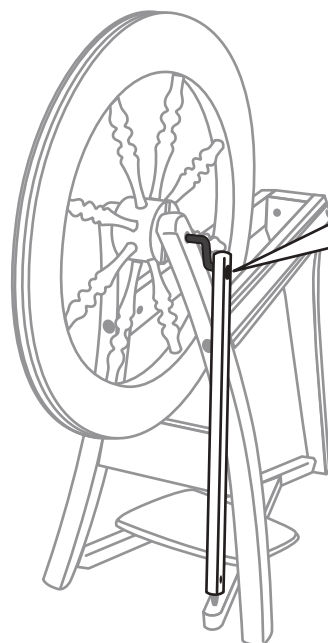

SINGLE DRIVE

Step 12 - 21 For Single Drive only. For Double Drive go to Step 22.



Screw 12 hooks into the flyer.

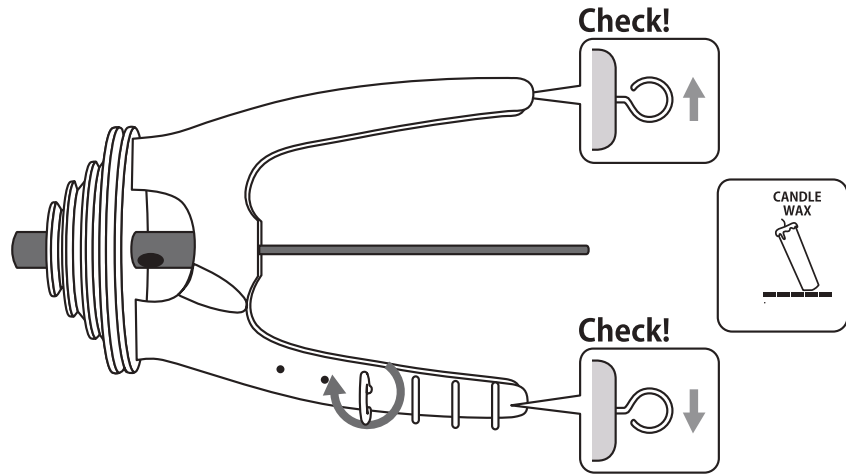

Assemble the flyer unit.

Check the shape of the nylon bearing on each maid upright, wax the dowel ends, then insert into the correct hole.

Insert the drive belt adjusting knob into the maiden bar, turn until the end just protrudes.

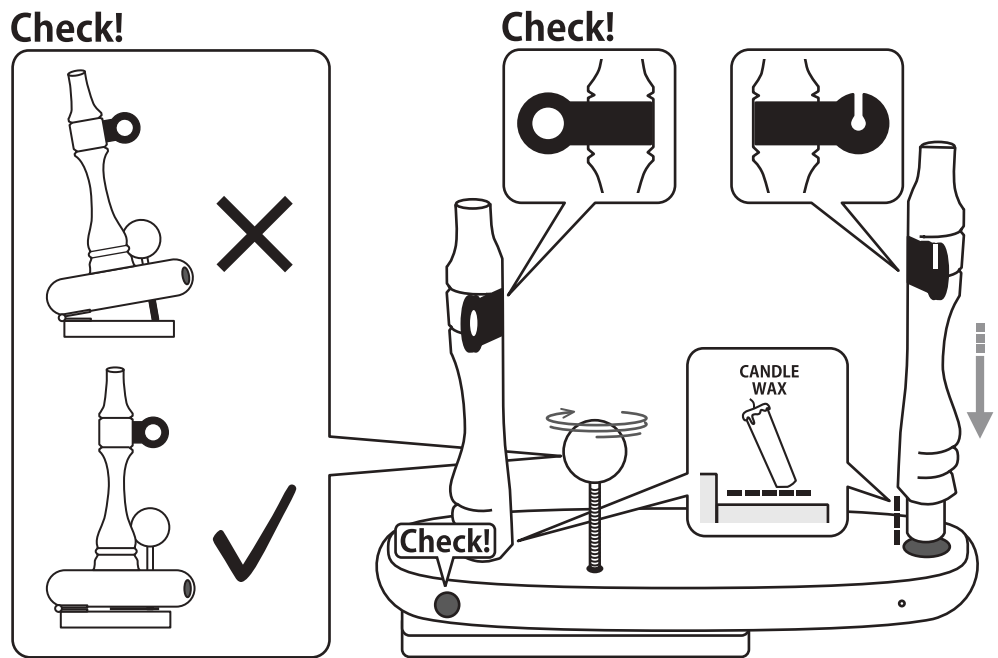

Check the angle of the nylon bearings. Then secure the maid uprights with screws and washers. Do not overtighten.

The maid uprights may be twisted to remove the bobbin.

Position the drawing pin directly beneath the drive band adjusting knob.

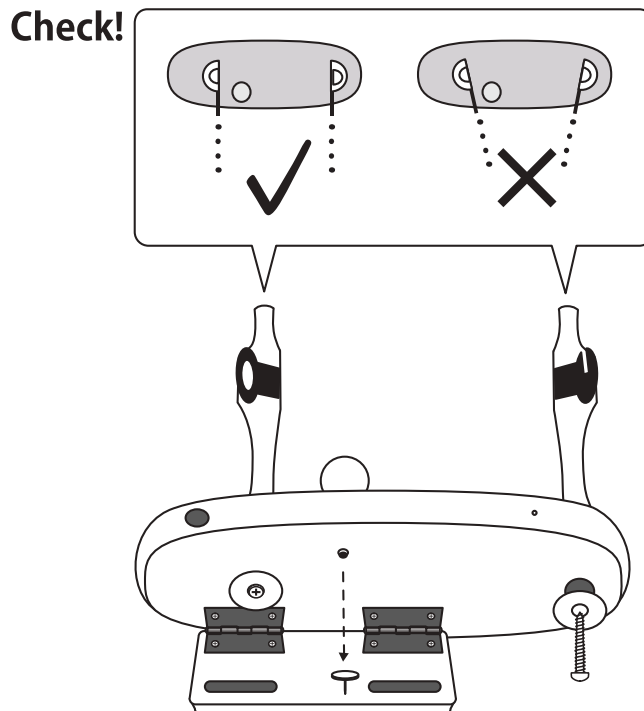
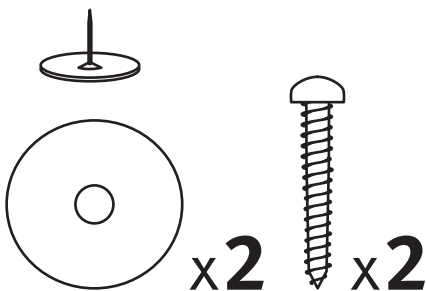

15



Apply a drop of oil to the flyer shaft and slide the small end of the bobbin on first. Ashford spinning wheel oil is ideal for this purpose. Then locate the flyer into the bearings. Thread the screw eye into the side of the maiden bar, and screw hook into the opposite side.

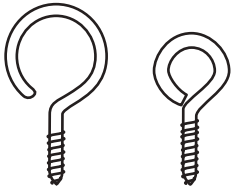
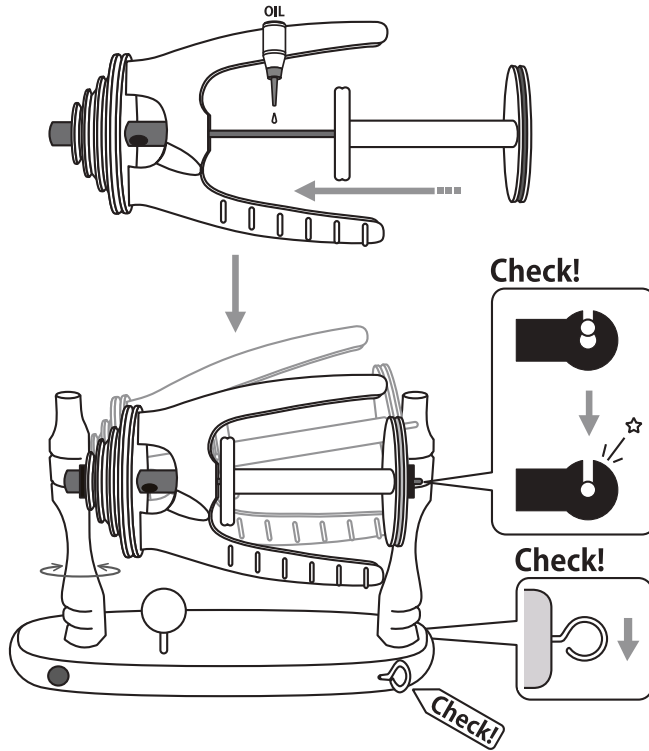

16



Attach the brake band. Thread it through the screw eye and then tie the springs as illustrated.

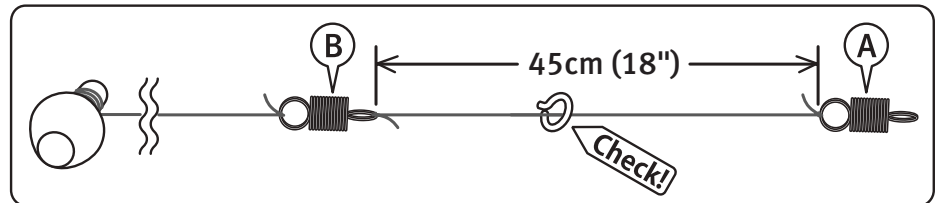
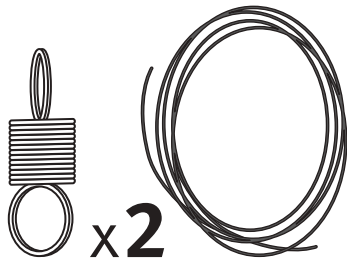
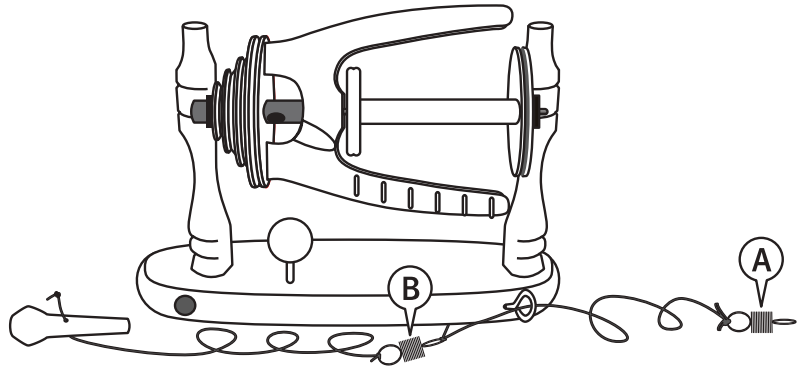

17



Put the brake band over the grooved end of the bobbin. Do not over stretch the springs.

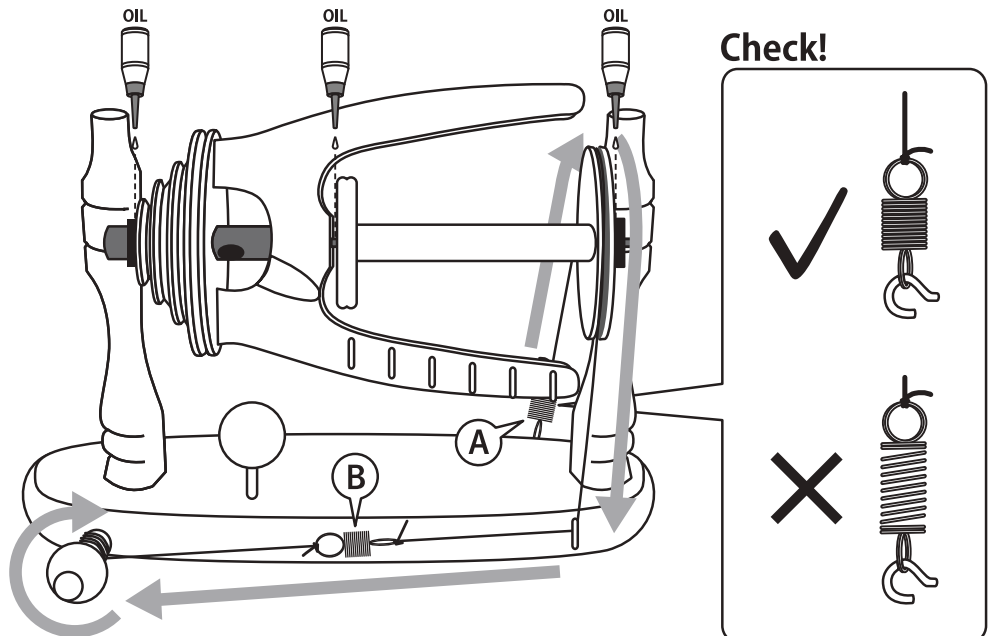

18

Tie the threading hook to the front maid upright with the cotton tape.

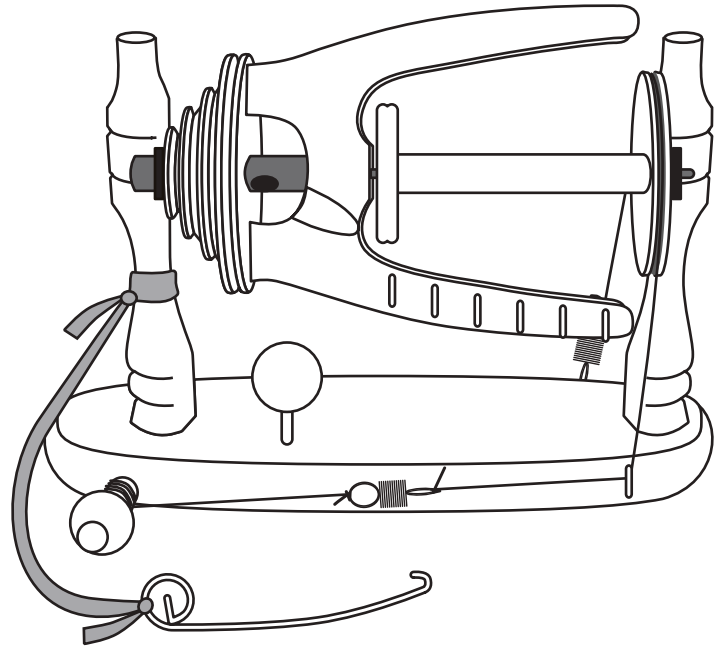
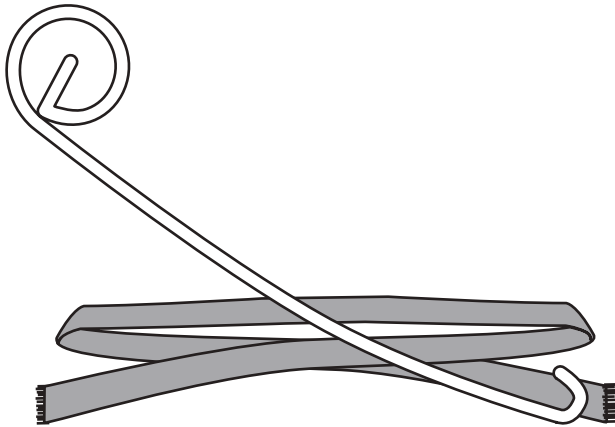

19



Attach the flyer unit to the side rails with 2 screws and washers, do not tighten yet.

Move the flyer unit until the wheel and large flyer pulley are aligned. Then tighten the screws.

Check!

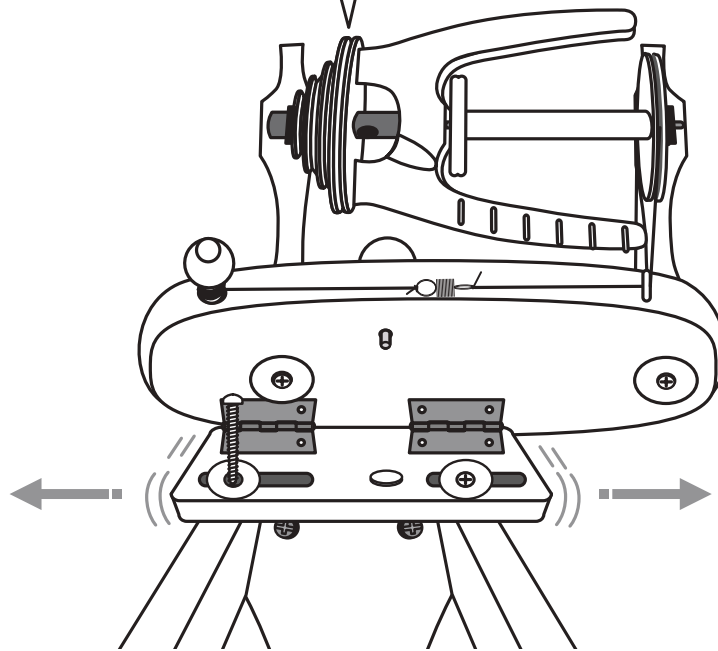
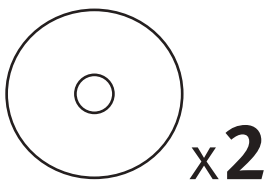
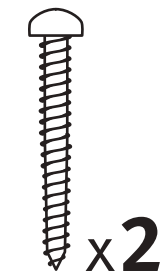
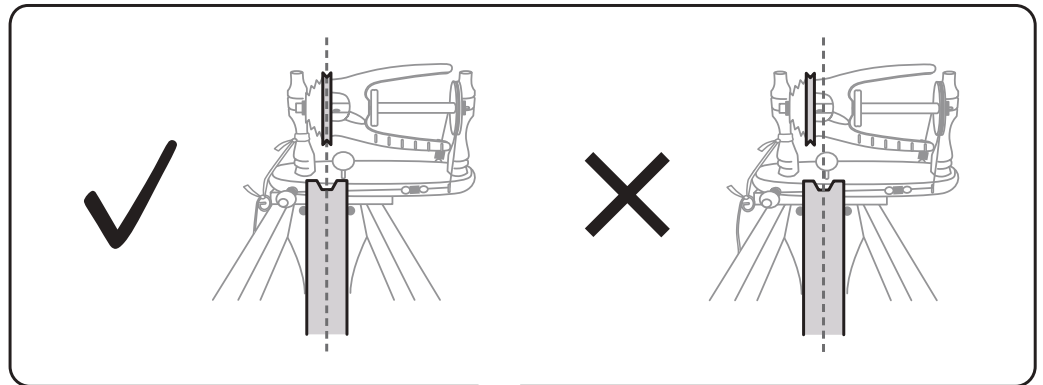

20



Check the end of the adjusting knob is not protruding beneath the maiden bar. Then place the drive belt around the wheel and large flyer pulley. Tie the drive belt and cut off the extra.



Check!

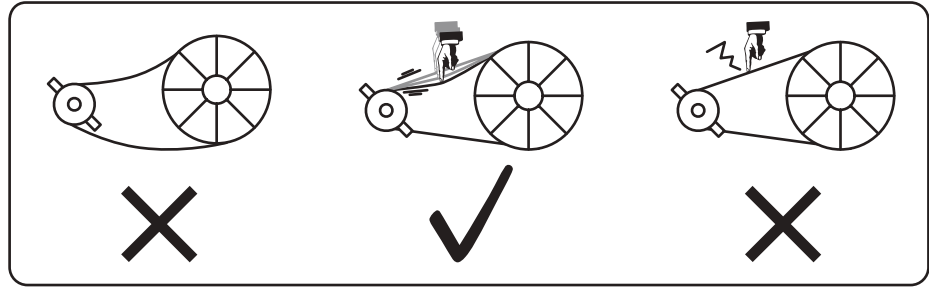

Check!

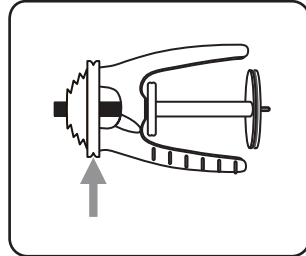

Check!

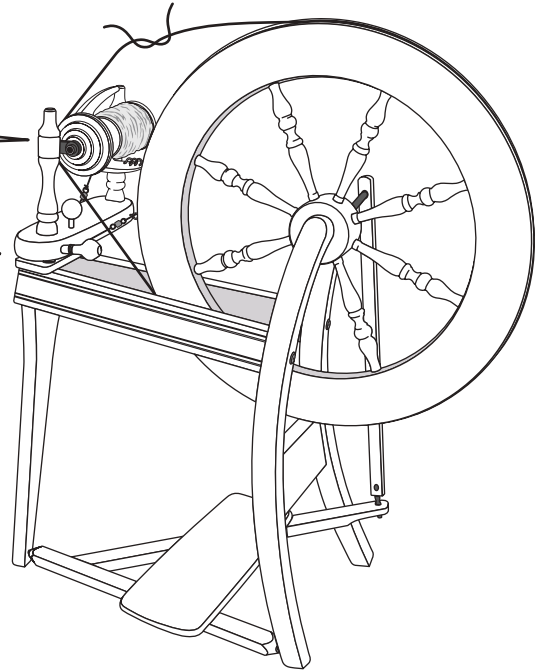
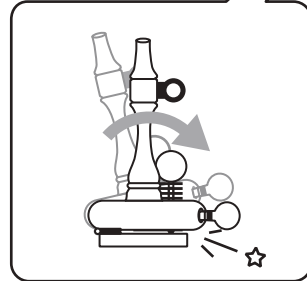

21

Single drive ratios:

The ratio with the drive belt around the large flyer pulley is approx. 7:1.

To spin a finer yarn while treading at the same speed, move the drive belt to one of the centre pulleys - either 9:1 or 12:1.

To spin a very fine yarn, move the drive belt onto the small flyer pulley and re-tension it. This ratio is approx. 17:1.

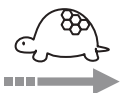
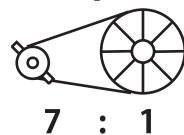
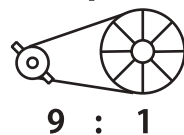
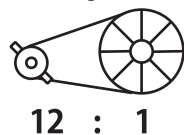
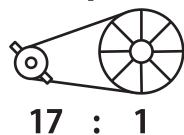
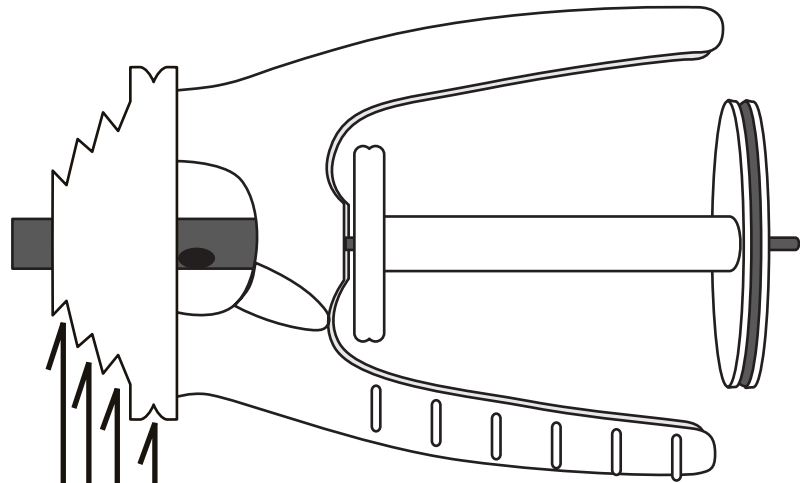

DOUBLE DRIVE

Step 22 - 32 For Double Drive only. For Single Drive go to Step 12.

22



Screw 12 hooks into the flyer.

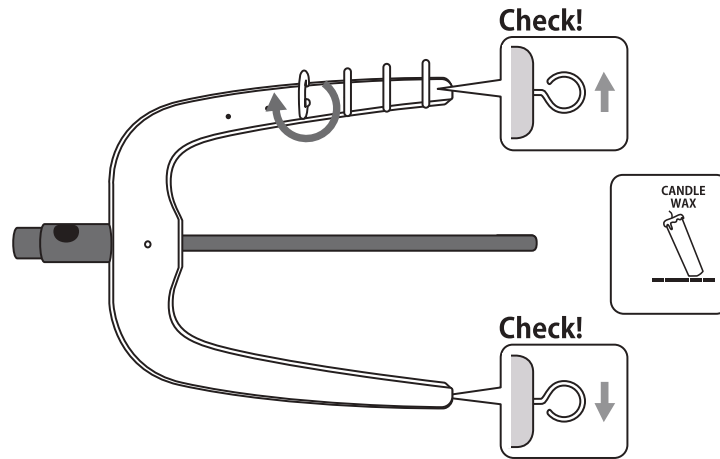

23

Assemble the flyer unit. Check the shape of the nylon bearing on each maiden upright, wax the dowel ends, then insert into the correct hole. Insert the drive belt adjusting knob into the maiden bar, turn until the end just protrudes.

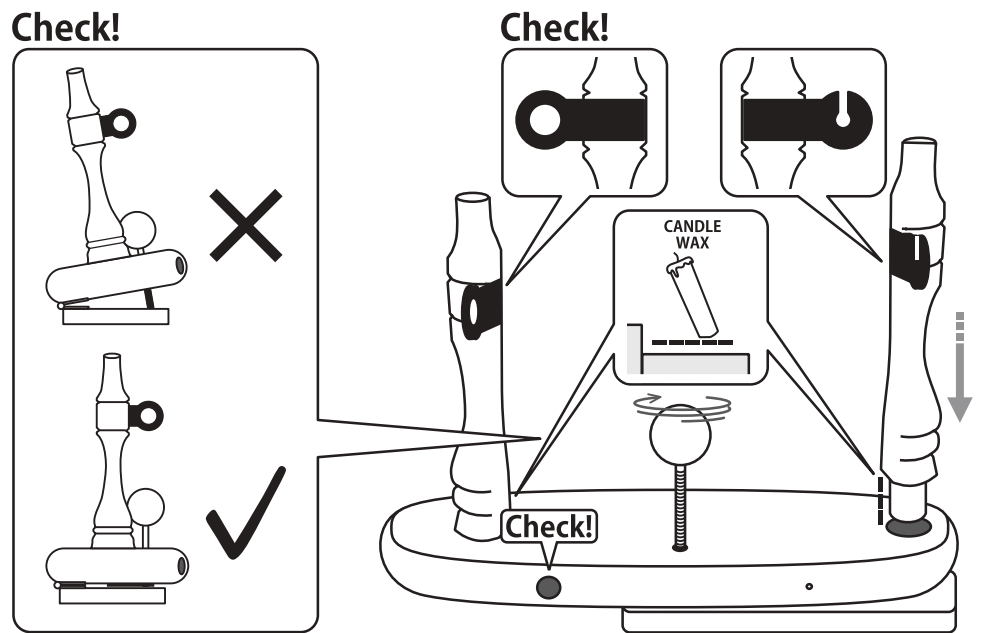

24



Check the angle of the nylon bearings. Then secure the maid uprights with screws and washers. Do not overtighten. The maid uprights may be twisted to remove the bobbin. Position the drawing pin directly beneath the drive band adjusting knob.

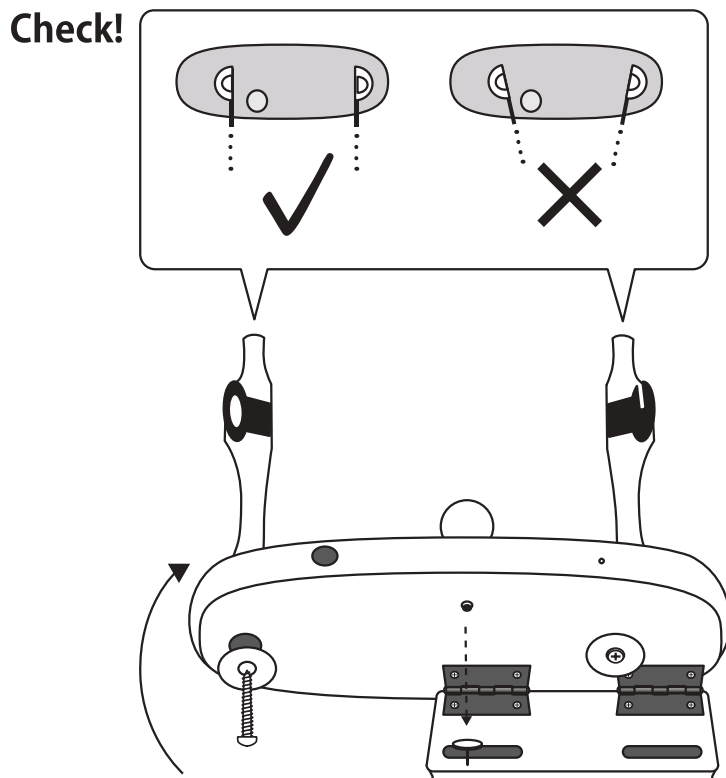
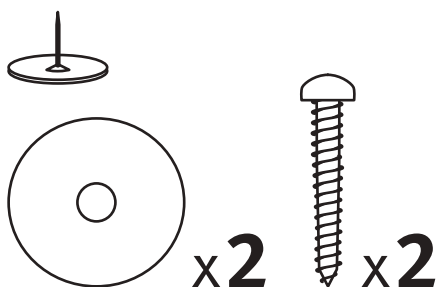

25



Apply a drop of oil to the flyer shaft and slide the bobbin on. Ashford spinning wheel oil is ideal for this purpose.

Partially locate the whorl onto the flyer shaft and rotate the whorl until the flat on the flyer shaft aligns with the flat in the whorl. Then push the whorl on.

Caution: Do not twist the whorl, only slide the whorl on or off. If it is tight apply a drop of oil to the end of the flyer shaft.

To change the bobbin, grip the whorl with one hand and the flyer with the other and pull the whorl directly off. Then locate the flyer into the bearings. Thread the screw eye into the side of the maiden bar, and screw hook into the opposite side.

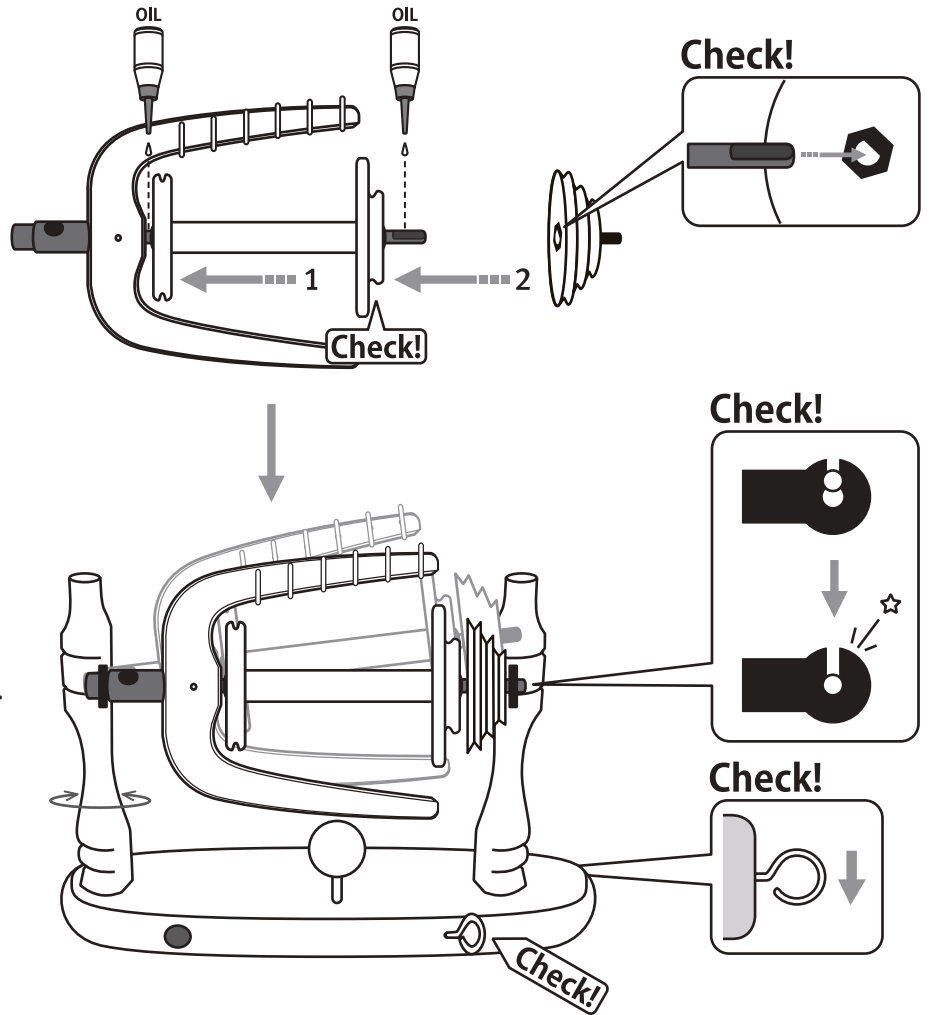
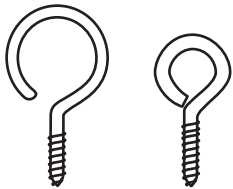

26



Attach the brake band. Thread it through the screw eye and then tie the springs as illustrated.

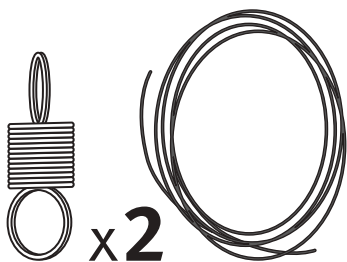
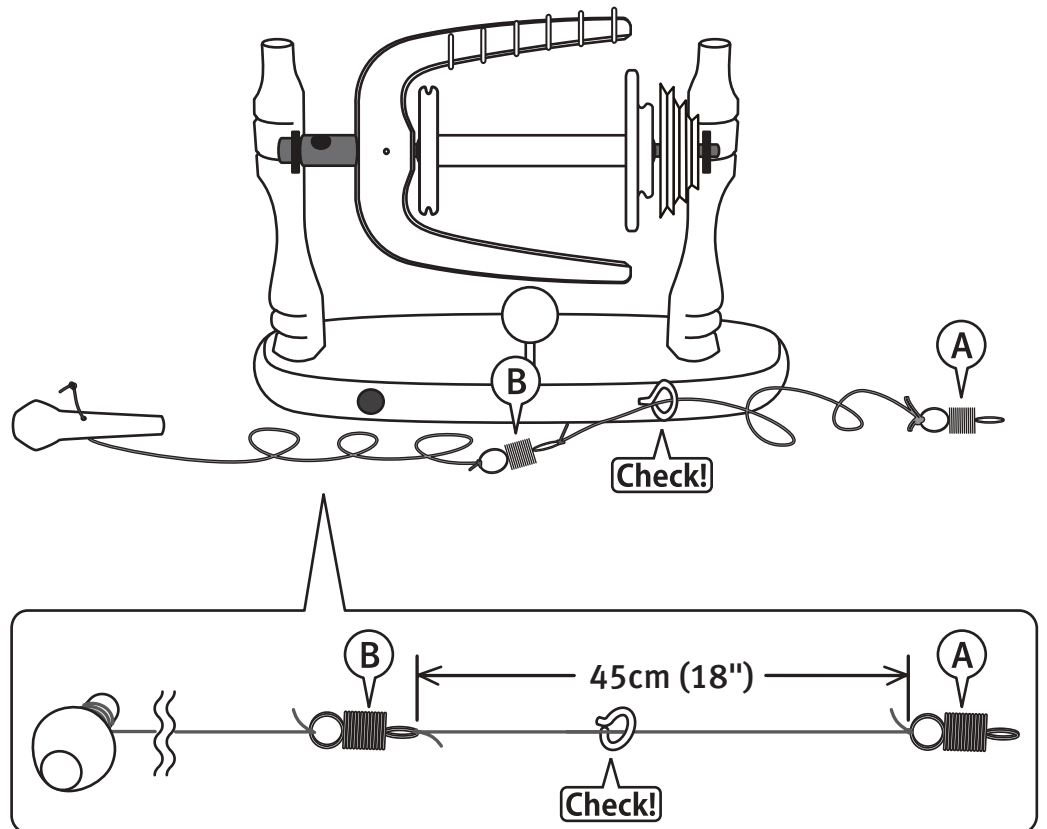

27 

This wheel can be used either double drive or single drive. When spinning double drive the brake band is stored around the back of the maid upright with the drive band around both the large flyer pulley and small bobbin pulley. When spinning single drive the drive band is around the large flyer pulley and the brake band is over either bobbin pulley. When using the brake band take care not to over-stretch the springs.

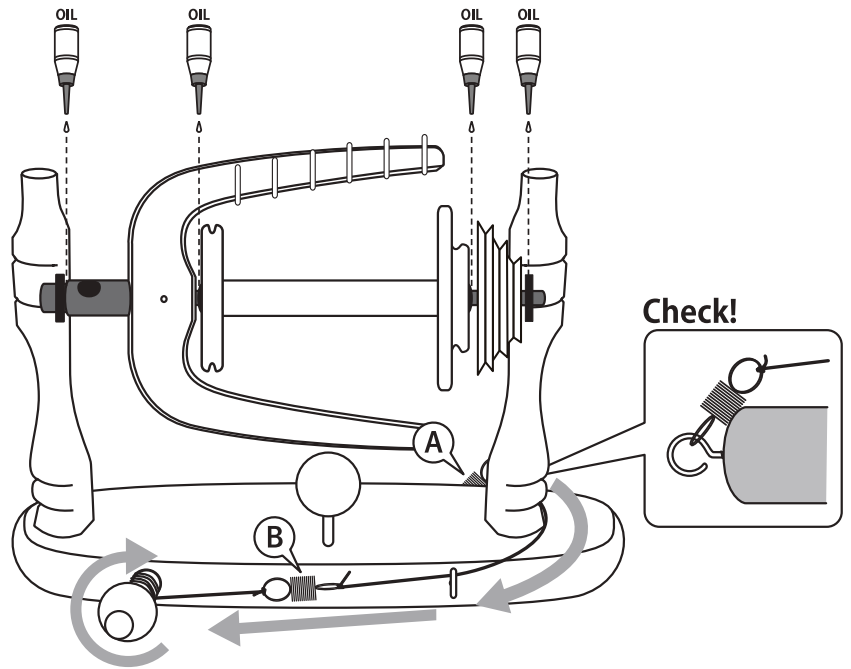

28

Tie the threading hook to the front maid upright with the cotton tape.

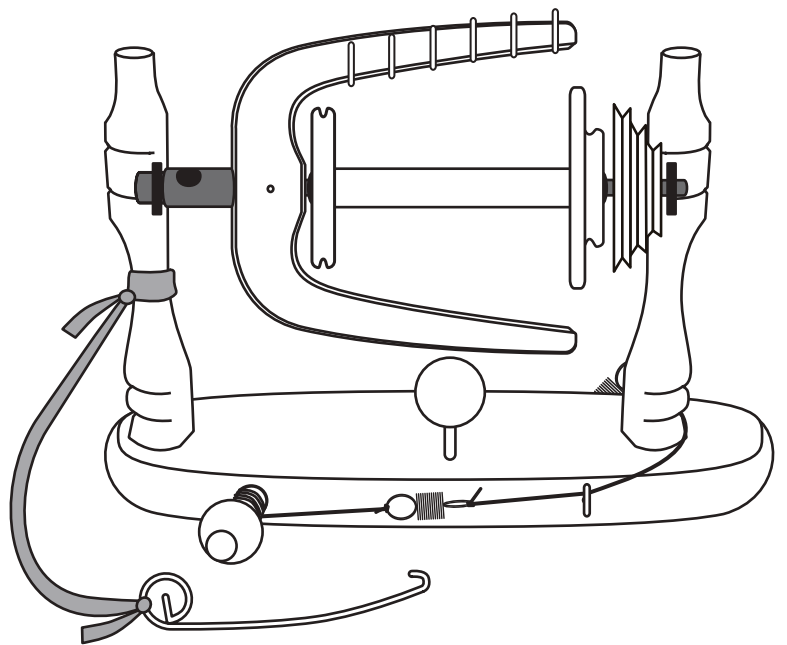
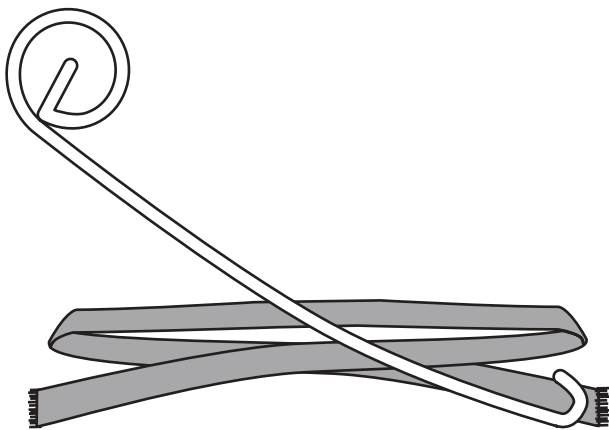

29  

Attach the flyer unit to the side rails with 2 screws and washers, do not tighten yet.

Move the flyer unit until the wheel and large flyer pulley are aligned. Then tighten the screws.

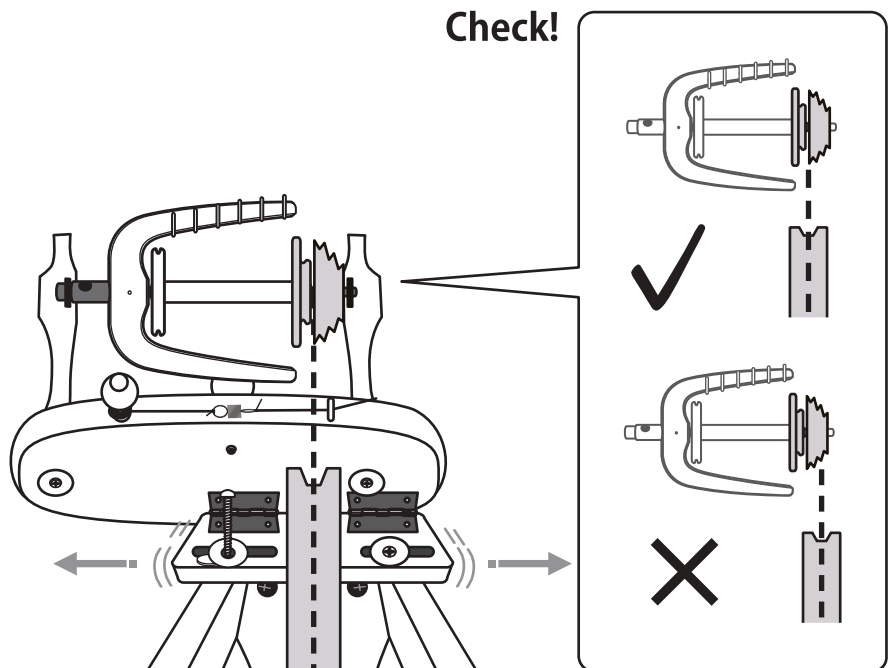
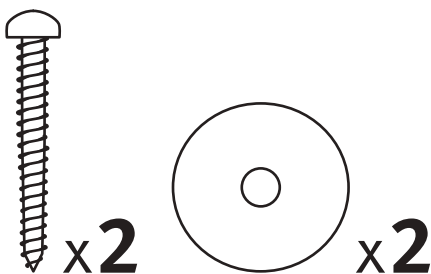

30



Check the end of the adjusting knob is not protruding beneath the maiden bar. Then place the drive belt around the wheel and large flyer pulley then around the wheel again and small bobbin pulley. Tie the drive belt and cut off the extra.

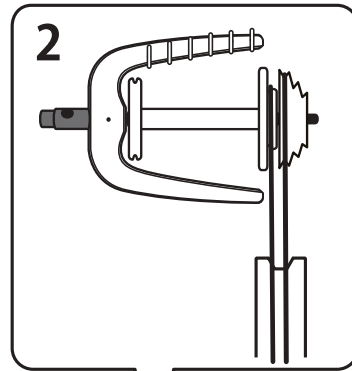
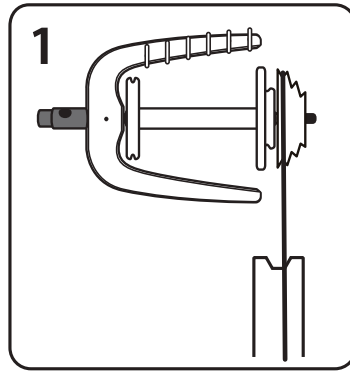
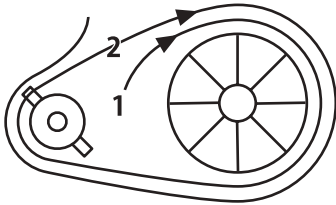

Check!

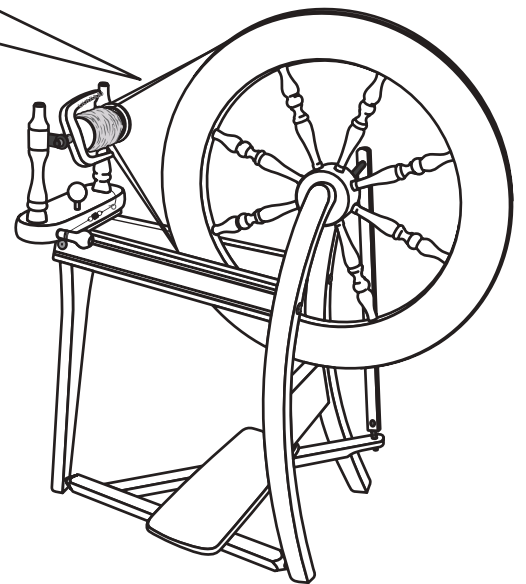
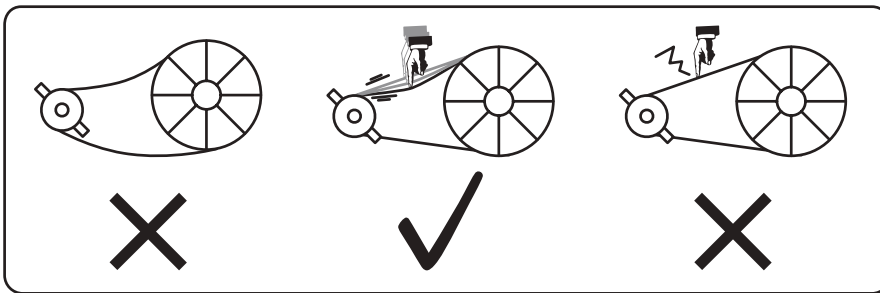
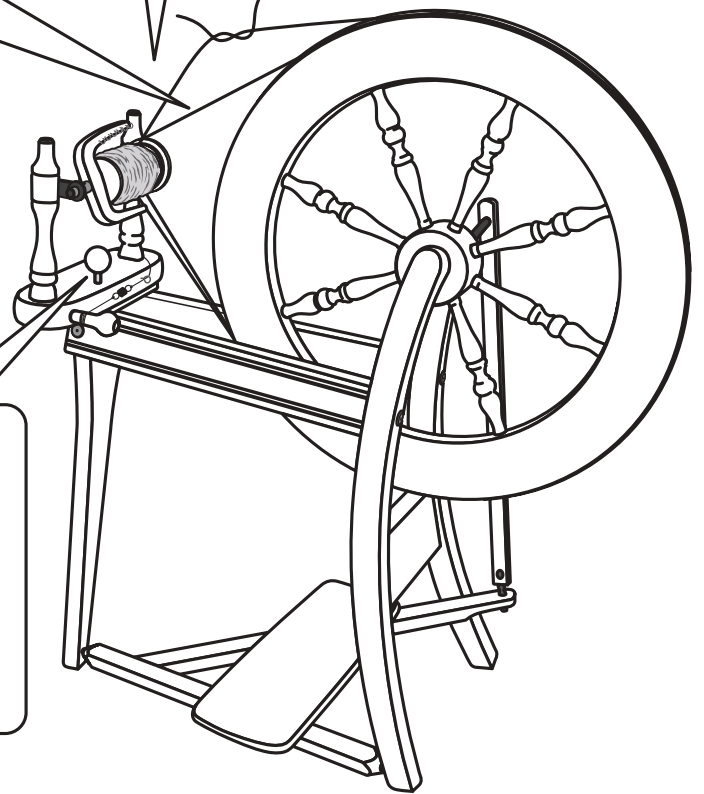
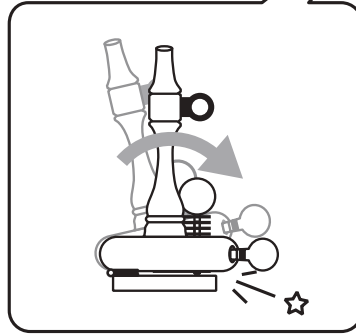

31

Double drive ratios:

The ratio with the drive belt around the large flyer pulley is approx. 7.5:1.

To spin a finer yarn while treadling at the same speed, move the drive belt to one of the smaller pulleys - either 9.5:1 or 13:1.

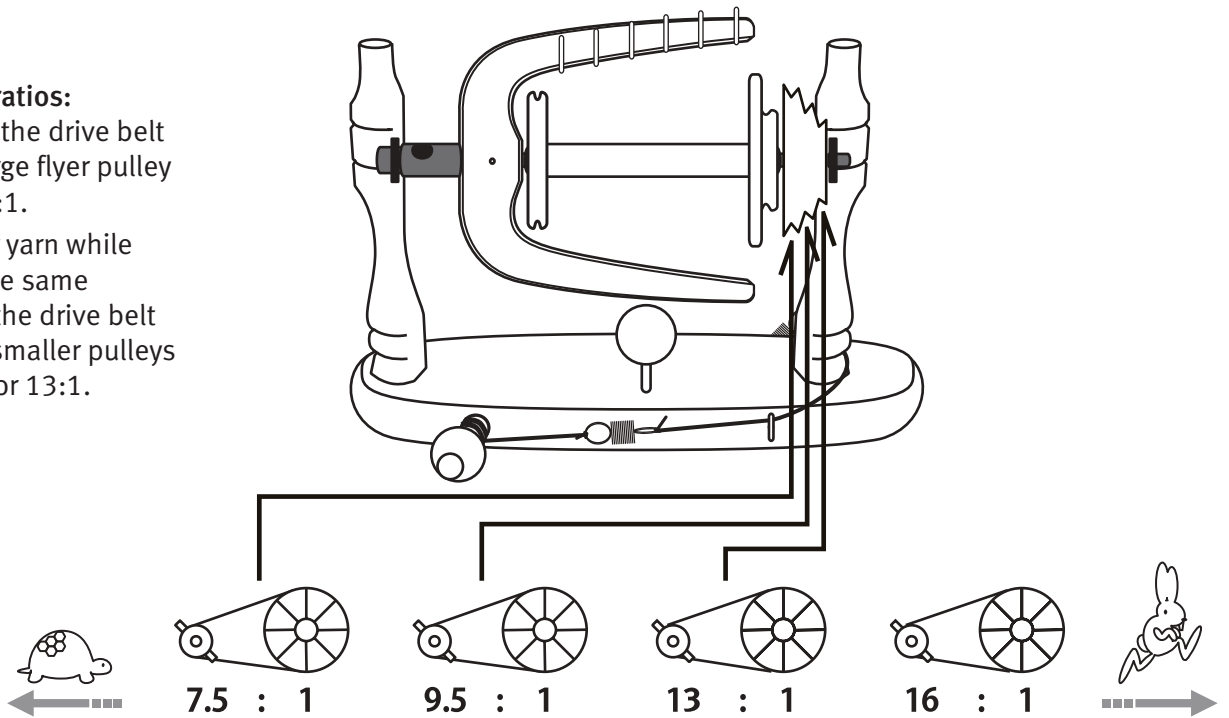

Bobbin lead:

Place both loops of the drive belt around the small bobbin pulley and re-tension it. Then place the brake band over the large flyer pulley. This ratio is approx. 16:1. Adjust the brake band tension so the springs only just begin to stretch.

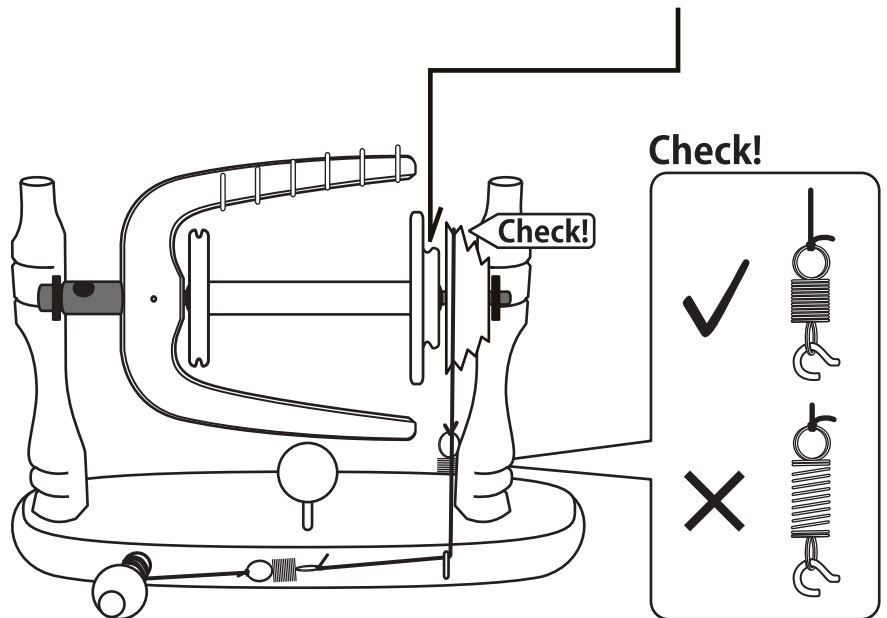

32

Single drive:

Place both loops of the drive belt around the large flyer pulley and the brake band over either bobbin pulley. Adjust the brake band tension so the springs only just begin to stretch.

To spin a finer yarn move both loops of the drive belt onto the small flyer pulley and re-tension it.

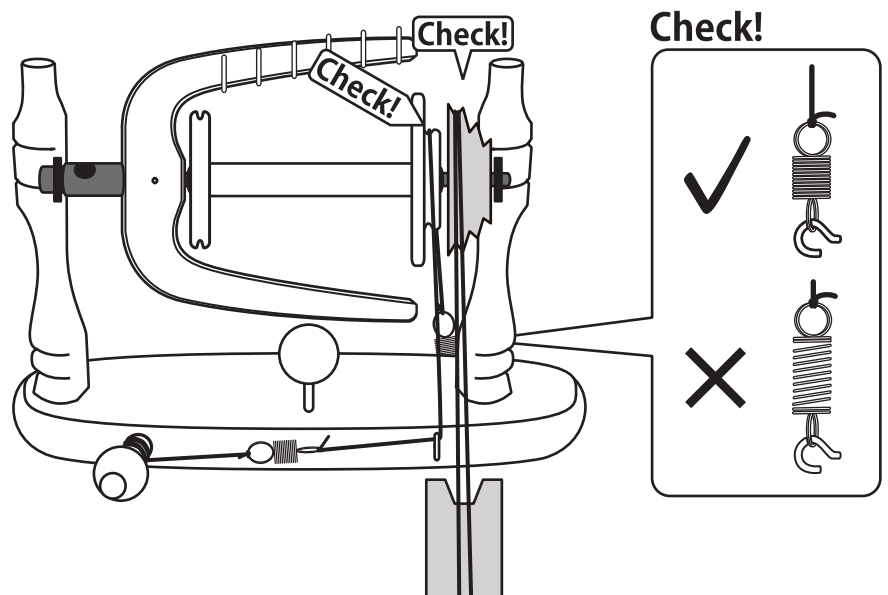

33

Assemble the Lazy Kate.
Note the countersunk holes on each upright
face inwards.

Check!

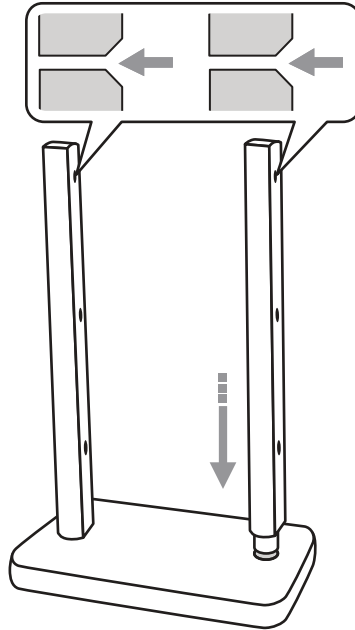

SINGLE DRIVE BOBBINS

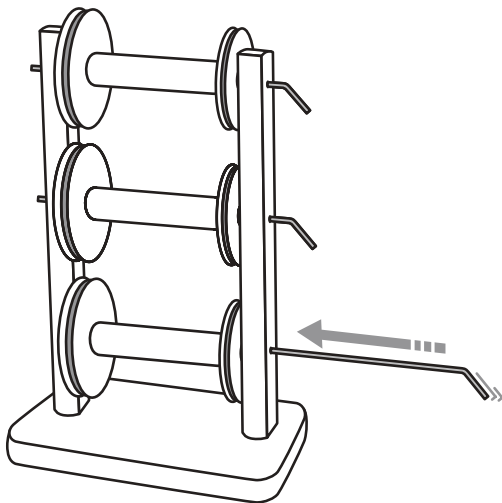

DOUBLE DRIVE BOBBINS

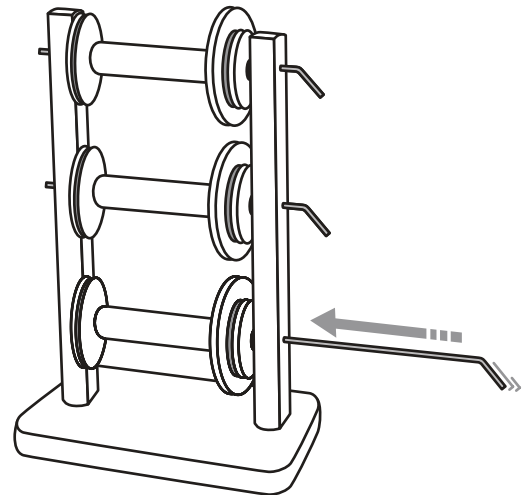

Memo

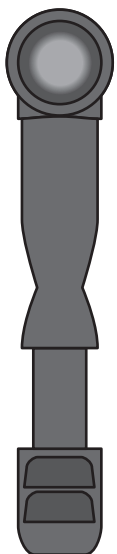

How to insert the polyurethane conrod joints into the conrod.
*This has been pre-assembled in the factory.

